

Hardrock

INSTRUCTIONS FOR USE

Codes 8202-8204



CONTENTS	PAGE
1.0 INTRODUCTION	2
2.0 ILLUSTRATION OF YOUR CHAIR	3
3.0 FOR YOUR SAFETY	4
4.0 UNPACKING YOUR CHAIR	5
5.0 SETTING UP AND ADJUSTING YOUR CHAIR	6
6.0 CARE & MAINTENANCE	10
7.0 GUARANTEE & SERVICE	11
8.0 CONTINUOUS IMPROVEMENT	11
9.0 WARRANTY & AFTERSALE	12

1.0 INTRODUCTION

Thank you for choosing the Hardrock. It is an extremely durable, robust and stable chair that has been specifically designed for children with complex learning difficulties and children who are inclined to rock when seated.

It provides a moderate level of postural support and a safe and secure environment to enable the children to engage in education, play and everyday activities necessary for their development. It is suitable for use at home and in schools.

IMPORTANT!

These instructions should be read by all therapists and carers using the equipment and should be retained for future reference. The Hardrock requires an assessment to establish goals and benefits as part of the users therapy programme and should always be used under professional guidance.

Any incorrect use of the product and failure to follow the instructions may put the user at risk or impede the function. If you have any queries using this product or wish for further copies, please do not hesitate to contact Customer Service department on
T: +44 (0) 1626 835552.

2.0 ILLUSTRATION OF YOUR CHAIR

HARDROCK SIZE 2 & 3
Code 8202-8203

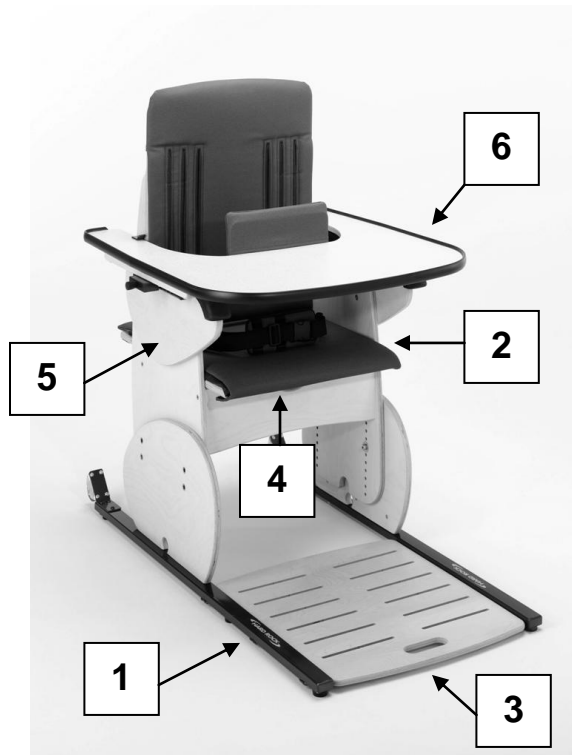

- 1.Ski
- 2.Pelvic strap
- 3.Footboard
- 4.Anti-thrust cushion
- 5.Armrest
- 6.Tray

HARDROCK SIZE 4
Code 8204

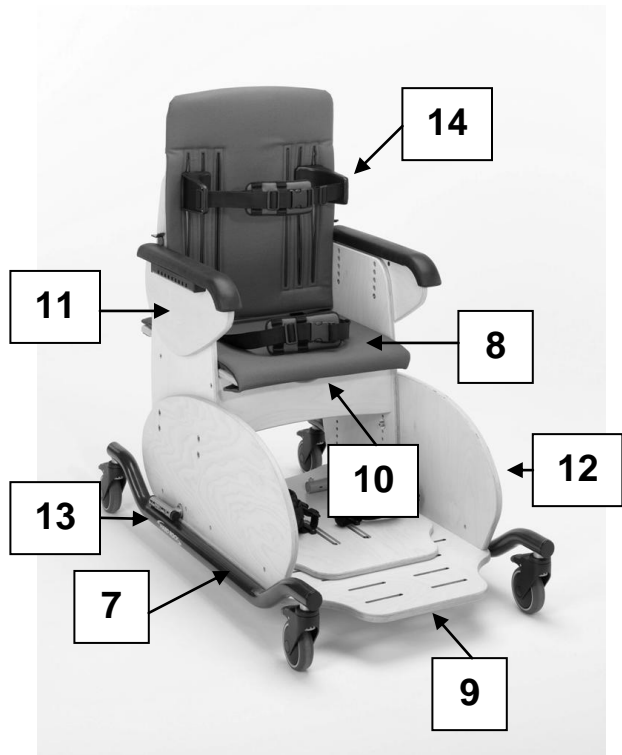

- 7.Mobile Base with lockable castors
- 8.Pelvic strap
- 9.Footboard
- 10.Anti-thrust cushion
- 11.Armrest
- 12.Extended gables (optional)
- 13.Stabilisers (optional)
- 14.Thoracic supports (optional)

Note: Size 4 also comes with tray as standard (not shown)

3.0 FOR YOUR SAFETY

PLEASE READ THESE INSTRUCTIONS BEFORE MAKING ANY ADJUSTMENTS.

- The user should NOT be left unattended whilst in the Hardrock. Always ensure a responsible therapist or carer is in attendance.
- For the initial setting up of the Hardrock and at subsequent/future reviews of the child, measurements of the child's seat depth and height is required.
- The therapist should be familiar with the methods of adjustment and have completed all adjustments appropriately to meet the needs of the child using the measurements taken before transferring the child into the chair.
- Adjusting the seat height of the Hardrock is easier and safer if carried out by two people.
- Ensure all castors on the mobile base are locked with castors facing inwards by tilting the chair slightly onto its side before making any adjustments.
- Rear transporter wheels have been fitted onto the skis to facilitate moving the chair. DO NOT use whilst the child is seated in the chair.

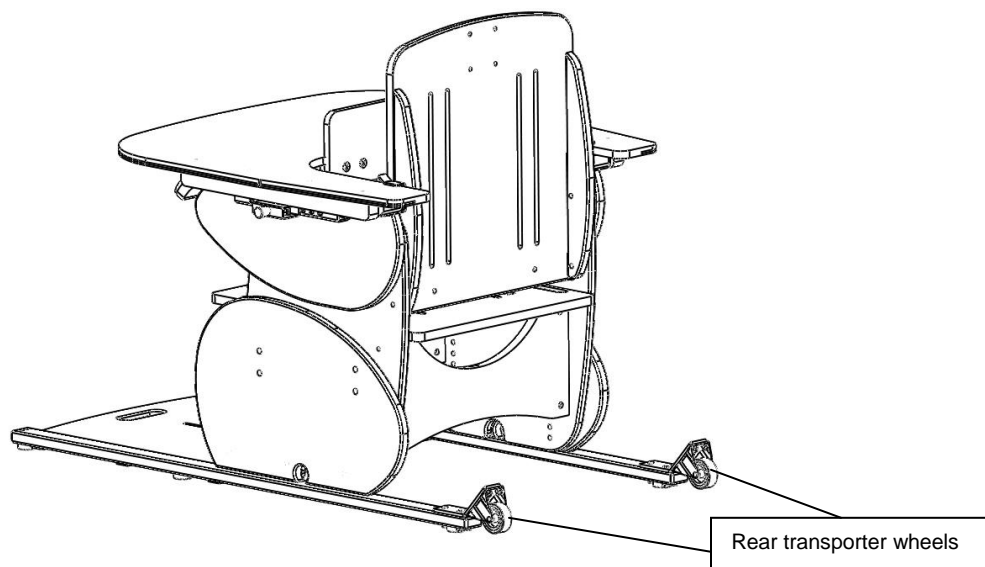

- If rear transporter wheels have not been fitted, Hardrock should only be moved by two people.
- Only Hardrock fitted onto mobile base can be used as an indoor transit chair.
- The Hardrock castors are designed for indoor use only and may be damaged if used outdoors.
- The Hardrock is only to be used on a flat level surface.
- **DO NOT EXCEED MAXIMUM WEIGHT LIMITS SPECIFIED.**
- Regular maintenance checks and cleaning are essential for the safe use of this equipment (see care and maintenance section).
- If any part is loose, damaged or functioning incorrectly, do not use until rectified.
- Always fasten the pelvic strap and any other straps provided.
- Regularly check that they are not showing any signs of tearing or fraying and that they fasten correctly.
- Ensure that all nuts, bolts and handwheels are securely tightened and that none are missing.
- Always keep this product away from naked flames, cigarettes and sources of heat including open fireplaces, radiators and heaters etc.
- **DO NOT** fit parts or accessories of other manufacturers to this product unless authorized to do so in writing by G&S Smirthwaite Ltd. Failure to follow these instructions will not only invalidate the guarantee but could make the chair dangerous to use. G&S Smirthwaite Ltd will not accept liability for any injury or damage incurred through such malpractices. Any repairs required must be carried out by G&S Smirthwaite Ltd authorized personnel.
- The Hardrock is CE marked. This certifies that it meets all relevant European safety requirements.

If you believe this product to be faulty - DO NOT USE - Contact G&S Smirthwaite Ltd on +44 (0) 1626 835552 or info@smirthwaite.co.uk.

4.0 UNPACKING YOUR CHAIR

- When delivered, the Hardrock will be supplied fully assembled except for the tray.
- Please take note of any instructions on the packaging/box when unpacking the chair.
- Once the chair has been carefully unpacked, please check all parts.
- If any part is loose, damaged or functioning incorrectly, do not use until rectified.

Should you wish to query any aspect of your product, please contact G&S Smirthwaite Customer Services on

T: +44 (0) 1626 835552
E: info@smirthwaite.co.uk.

5.0 SETTING UP AND ADJUSTING YOUR CHAIR

Set up is made safer and easier by following the instructions below.
2 sets of Hexagon keys are provided for the adjustment.



PLEASE NOTE

ALWAYS LOCK THE CASTORS WHEN ATTACHING ITEMS OR MAKING ADJUSTMENTS. TO LOCK, APPLY FOOT TO POINT (A) TO UNLOCK APPLY FOOT TO POINT (B)

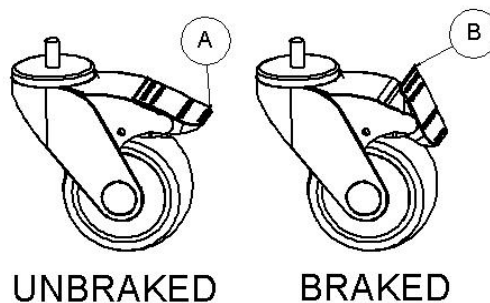

ALWAYS TURN LEVER LOCKS, HANDWHEELS AND SCREWS CLOCKWISE TO TIGHTEN OR ANTI-CLOCKWISE TO LOOSEN.

5.1 SEAT

5.1.1 SEAT ADJUSTMENTS

Two adjustments can be made to the seat; height and depth.

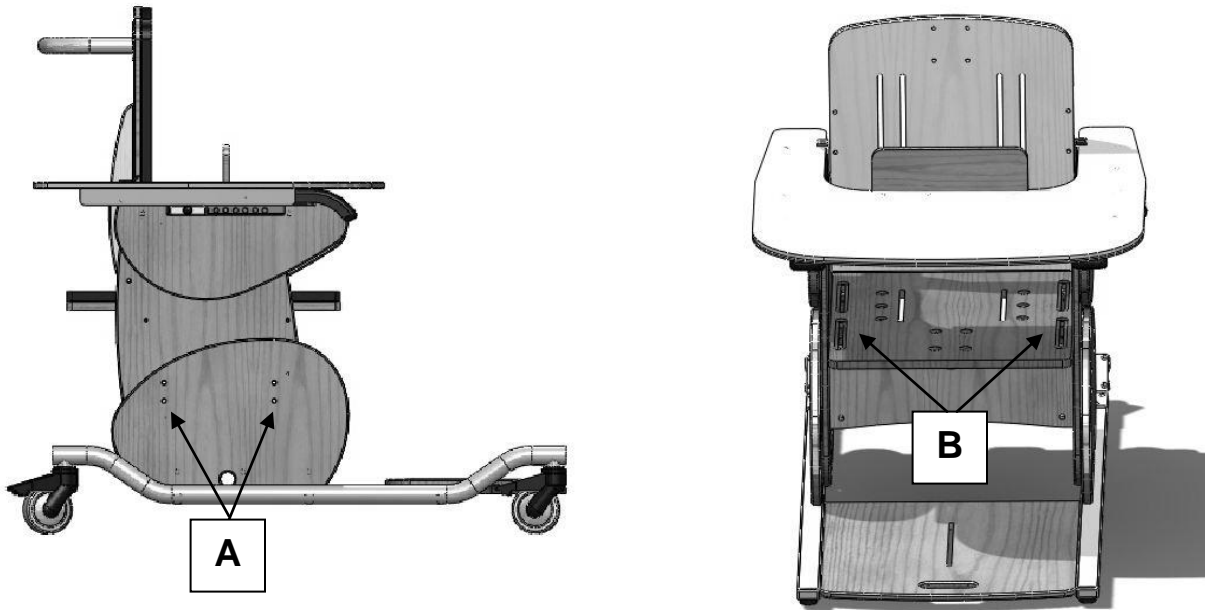

5.1.2 HEIGHT

- Lay the chair on its side. (2 people required).
- Remove the 4 hexagon head screws (A) on each side.
- With one person holding the top seat section of the chair, slide the seat section to the required height.
- Replace the 8 screws.
- Ensure all 8 screws match each other equally in height holes.
- Tighten the screws.
- Return chair to upright position.

5.1.3 DEPTH

- Lift the front edge of the seat pad attached with Velcro under the seat.
- Loosen the 4 hexagon screws (B) in the slots on the edge of the seat by a just a couple of turns.
- Slide the seat back or forwards to desired depth.
- Tighten the screws.

5.2 ARMREST

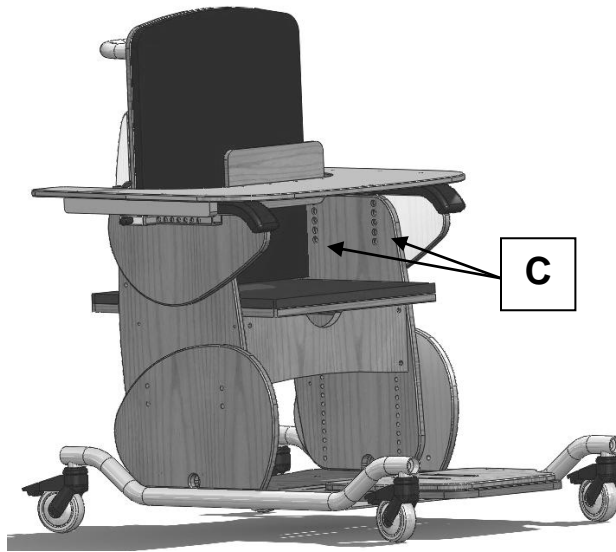

- Loosen the 2 hexagon screws (C).
- Position at required height using any of the holes available.
- Tighten the screws.
- Ensure that both armrests are set at the same height and horizontal.

5.3 TRAY

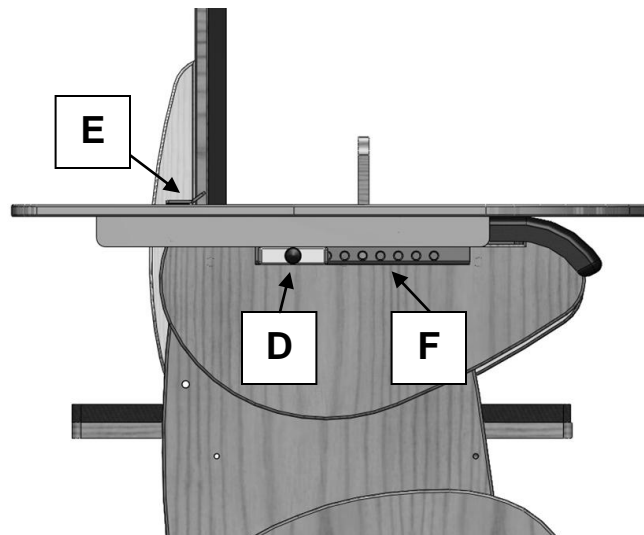

- Hold the sides of the tray.
- Pull 2 plunger pins (D) out to rest and park at an angle.
- Rest back of tray on armrest.
- Slide back of tray under the tray retainer (E) and then to desired position.
- Release pins securely into position in the holes along the armrest (F).
- Ensure chest pad is correctly positioned in front of child for safety, appropriate support and reduce undesired movement.

5.4 THORACIC SUPPORTS

Two adjustments can be made to the thoracic supports; size 3 upwards.

5.4.1 HEIGHT

To adjust:

- Loosen handwheels on rear of seat.
- Move the thoracic support up or down to desired position.
- Re-tighten the handwheels.

5.4.2 WIDTH

To adjust:

- Loosen handwheels on rear of seat, and remove from the vertical slots.
- Position the thoracic support appropriate vertical slot for the desired width.
- Re-tighten the handwheels.



5.5 STRAPS

- The buckle is secured by pushing (G) into (H).
- To release the buckle, press both sides of (G).
- The strap length can be altered by adjusting the tri-glide (as shown opposite)

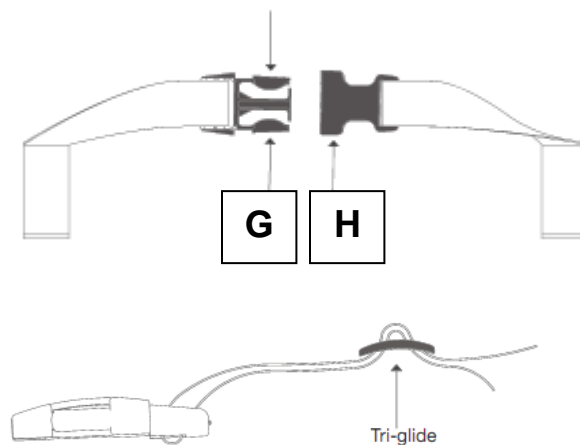

5.6 HEELSTOP FOR HEEL HUGGY ACCESSORY

The heel stop can be adjusted in depth.

- Loosen the screws (I) by a couple of turns.
- Slide it back or forwards to desired depth.
- Re-tighten screws.

5.7 POMMEL

Pommels have to be specified at the time of order. A pommel cannot be retrofitted.

To adjust:

- Loosen hand wheel.
- Position the pommel in or out to the desired position.
- Re-tighten handwheels.

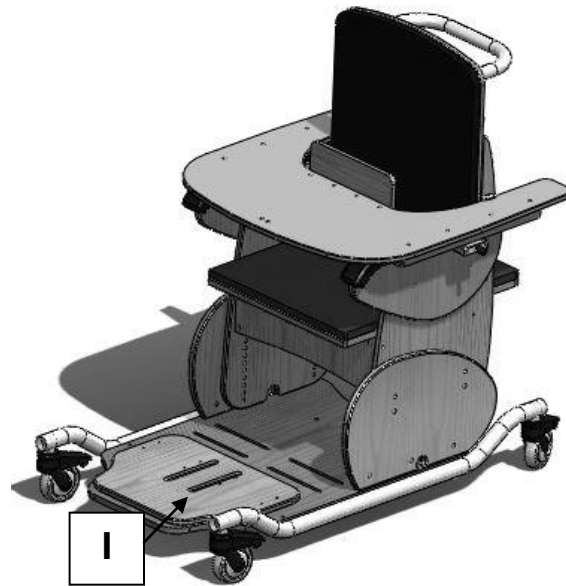

5.8 STABILISERS

Stabilisers can be ordered as an accessory at time of order or retrofitted, giving additional stability to the Hardrock product.

5.8.1 Retrofitting

- Slacken side panel fixing screws located under the chassis.
- Insert stabilizers through the 'mouse-hole' (J) of the side panel.
- Turn the stabilizer to the vertical position (as shown above).
- If needed, drill M8 clearance hole through the baseboard.
- Secure stabilizers with M8 cap screws, nuts and washers.
- Re-tighten leg/side panel fixing screws under the chassis.

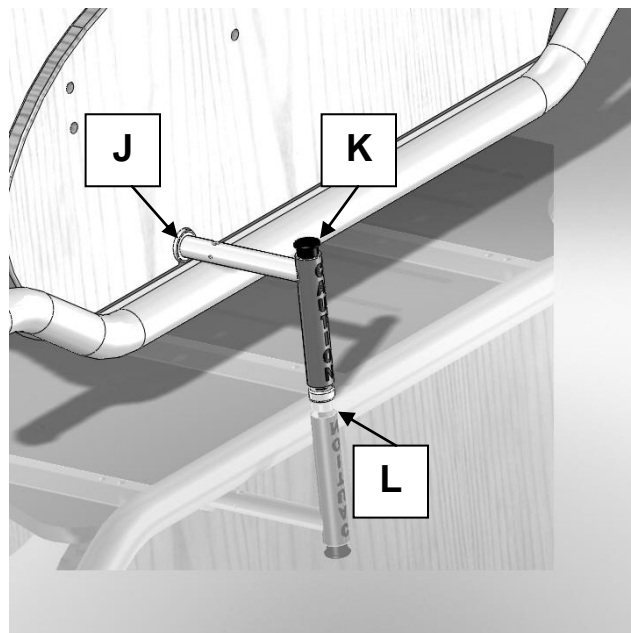

5.8.2 Extend stabiliser

- Depress button (K).
- Pull stander tube out (L).
- Release button.
- Turn it vertical to the ground - there will be an audible click when locked.

6.0 CARE AND MAINTENANCE

All our wooden chairs are easy to clean. Each chair has anti-bacterial properties ensuring that surfaces are kept hygienic to reduce any risk of cross infection.

- Clean upholstery and wooden parts with a damp cloth and mild detergent.
- Stubborn marks on the woodwork should be cleaned by using a soft brush.
- Do not soak or immerse the chair in water.
- The pelvic strap can be cleaned with a damp cloth. In cases of extreme soiling it can be machined washed at low temperature with mild detergent but must be drip dried.
- Store the chair in a cool dry place and out of direct sunlight.
- DO NOT use bleach, solvents, abrasives, synthetic detergents, wax polishes, antibacterial sprays or wipes.
- For further information please refer to MHRA or your NHS cleaning guidelines.

! CAUTION

REGULAR MAINTENANCE CHECKS ARE RECOMMENDED. THE USER SHOULD NOT BE SEATED WHILE THE CHECKS ARE CARRIED OUT.

6.1 DAILY CHECKS

- Check the product for damage or loose components.
- Check all upholstery for signs of wear and tear.
- Check the straps for signs of wear and tear.
- Check the castors are running freely and brakes are in working order.

6.2 MONTHLY CHECKS

- Repeat daily checks.
- Check all mechanical movements operate fully.
- Check the structure of the product for signs of damage, wear and tear.

6.3 ANNUAL SERVICE

The Hardrock chair should be serviced annually. Servicing must only be undertaken by a Smirthwaite service engineer, or by a Smirthwaite trained representative.

7.0 GUARANTEE & SERVICE

The Hardrock is issued with a full parts and labour guarantee for 2 years from the date of delivery. This guarantee does not apply to accidental damage caused through inappropriate use of the Hardrock. This guarantee is issued at the discretion of G&S Smirthwaite Ltd on RTB (Return to Base) basis. If you have any questions or doubts relating to the safety or use of the chair please contact us for advice or assistance on:

T: +44 (0) 1626 835552
E: info@smirthwaite.co.uk

8.0 CONTINUOUS IMPROVEMENT

G&S Smirthwaite Ltd are committed to continuous improvement to their product range. Should you have any suggestions or comments please send them to our product design department at: info@smirthwaite.co.uk

G&S Smirthwaite Ltd reserve the right to change the specification or material without prior notice.

For catalogues, help and further information on our products please contact us at:

G&S Smirthwaite Ltd
17 Wentworth Road
Heathfield
Devon TQ12 6TL

T: +44 (0) 1626 835552
F: +44 (0) 1626 835428

E: info@smirthwaite.co.uk
W: www.smirthwaite.co.uk



G&S Smirthwaite, 17 Wentworth Road, Heathfield, Newton Abbot, Devon.TQ12 6TL
T: +44 (0) 1626 835552 F: +44 (0) 1626 835428 E: info@smirthwaite.co.uk
W: www.smirthwaite.co.uk