

Portable Hip Spica

INSTRUCTIONS FOR USE

Code 5596



CONTENTS	PAGE
1.0 INTRODUCTION	1
2.0 ILLUSTRATION OF YOUR CHAIR	2
3.0 FOR YOUR SAFETY	2
4.0 UNPACKING YOUR CHAIR	3
5.0 SETTING UP AND ADJUSTING YOUR CHAIR	3
6.0 CARE & MAINTENANCE	8
7.0 GUARANTEE & SERVICE	9
8.0 CONTINUOUS IMPROVEMENT	9
9.0 WARRANTY & AFTERSALE	10

1.0 INTRODUCTION

Thank you for choosing the Smirthwaite Portable Hip Spica Chair.

Designed to be tool free, highly adjustable and lightweight, the chair is portable and can be dismantled for storage.

The low seat height allows the child to engage in education, play and everyday activities at peer level while in plaster. It is suitable for use in therapy units, schools and at home.

IMPORTANT!

These instructions should be read by all therapists and carers using the equipment and should be retained for future reference. The chair should always be used under professional guidance and adult supervision.

Any incorrect use of the product and failure to follow the instructions may put the user at risk or impede the function. If you have any queries using this product or wish for further copies, please do not hesitate to contact Customer Service department on T: +44 (0) 1626 835552.

2.0 ILLUSTRATION OF YOUR CHAIR

- A. Seat
- B. Backrest
- C. Armrest
- D. Tray

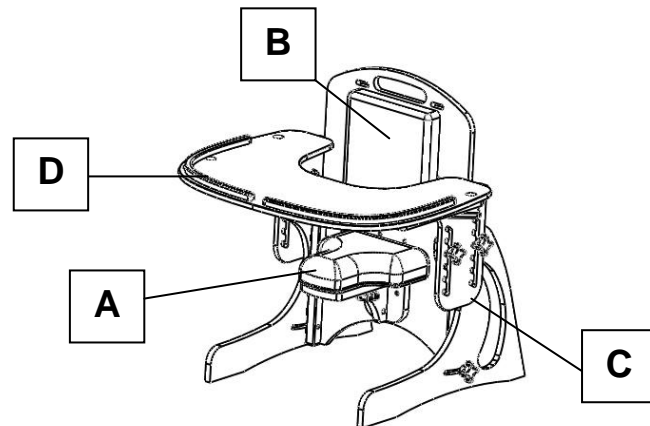

3.0 FOR YOUR SAFETY

PLEASE READ THESE INSTRUCTIONS CAREFULLY AND THOROUGHLY

- The user should **NOT** be left unattended whilst in the chair. Always ensure a responsible therapist or carer is in attendance.
- The carer should be familiar with the methods of adjustment and have completed all adjustments appropriately to meet the needs of the child before transferring the child onto the chair.
- Regular maintenance checks and cleaning are essential for the safe use of this equipment (see care and maintenance section).
- Ensure that all nuts, bolts and handwheels are securely tightened and that none are missing.
- The chair is **ONLY** to be used indoors on a flat level surface.
- Always fasten the pelvic strap and any other straps provided with the chair.
- Always keep this product away from naked flames, cigarettes and sources of heat including open fireplaces, radiators and heaters.
- **DO NOT** fit parts or accessories of other manufacturers to this product unless authorised to do so in writing by G&S Smirthwaite Ltd. Failure to follow these instructions will not only invalidate the guarantee but could make the chair dangerous to use. G&S Smirthwaite Ltd will not accept liability for any injury or damage incurred through such malpractices. Any repairs required must be carried out by G&S Smirthwaite Ltd authorised personnel.
- If you believe the chair or any fitted accessory to be faulty at any time, **DO NOT USE** – contact Smirthwaite by telephone on +44 (0) 1626 835552.

4.0 UNPACKING YOUR CHAIR

- When delivered, the chair will be supplied fully assembled except for the attachment of any accessories ordered.
- If your order has been supplied as a custom kit, please ensure you follow both the instructions documented in this IFU **and** any additional instructions supplied.
- Please take note of any instructions on the packaging/box when unpacking.
- Once the chair has been carefully unpacked, please check all parts.

If you believe this product to be faulty - **DO NOT USE** - Contact G&S Smirthwaite Ltd on T: +44 (0) 1626 835552.

5.0 SETTING UP AND ADJUSTING YOUR CHAIR

Set up is made safer and easier by following the instructions below.



PLEASE NOTE: ALWAYS TURN LEVER HANDWHEELS AND SCREWS CLOCKWISE TO TIGHTEN OR ANTI-CLOCKWISE TO LOOSEN. THE CHAIR MUST BE FULLY ADJUSTED BY A THERAPIST OR TRAINED REPRESENTATIVE BEFORE USE.

5.1 SEAT ADJUSTMENTS

Four adjustments can be made to the seat; height, depth, seat angle and tilt

5.1.1 HEIGHT

To raise or lower the seat:

- Remove handwheels and washers (A)
- Position seat at the desired height to the nearest pair of holes – there are 5 preset heights available (B)
- Replace handwheels and washers (A)
- Ensure the handwheels are sufficiently tightened prior to use

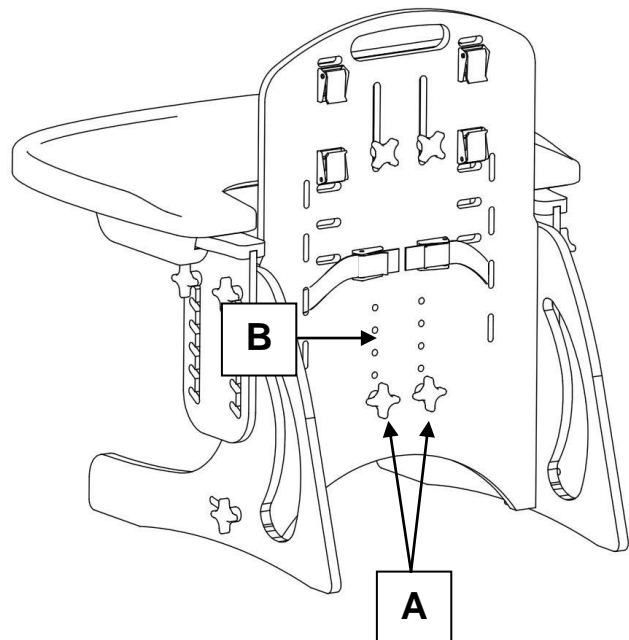

5.1.2 DEPTH

To move the seat cushion backwards and forwards

- Loosen the handwheels (C)
- Slide seat to the desired position
- Retighten the handwheels, ensuring they are sufficiently tight prior to use

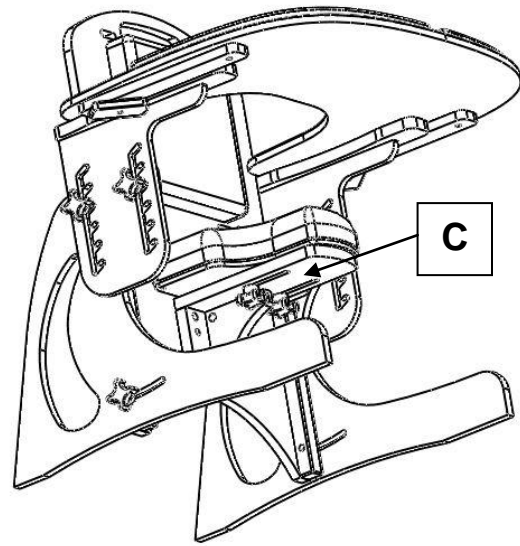

5.1.3 ANGLE

To adjust the seat cushion angle

- Place the chair on its side
- Remove handwheel (D)
- The seat cushion can now be adjusted in angle to one of 3 preset positions
- When the desired position is selected, insert the handwheel (D) and ensure it is tightened prior to use

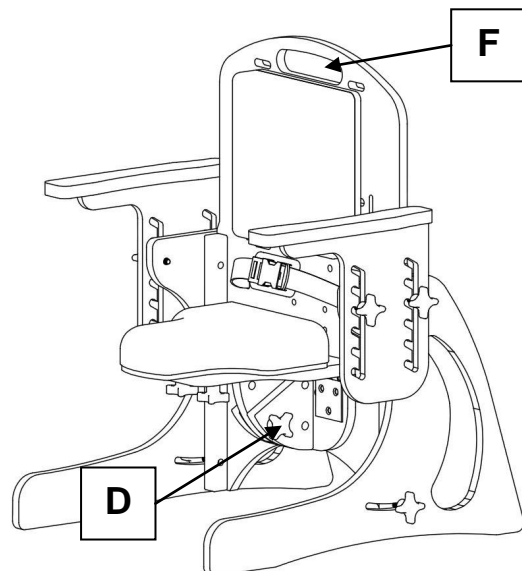

5.1.3 TILT

To position seat upright or tilt backward

- Loosen handwheels (E) on both sides of the chair.
- Hold the handle (F) and tilt the chair to the desired position
- Tighten handwheels (E) prior to use

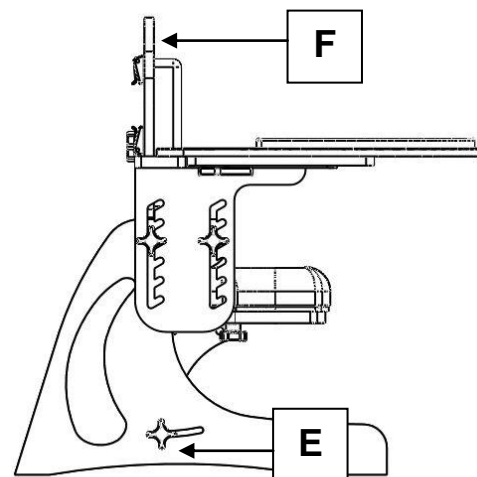

5.2 BACK ADJUSTMENTS

5.2.1 HEIGHT

To raise or lower the back pad cushion

- Loosen the handwheels (G)
- Slide the back cushion to the desired position
- Retighten the handwheels (G), ensuring they are sufficiently tight prior to use

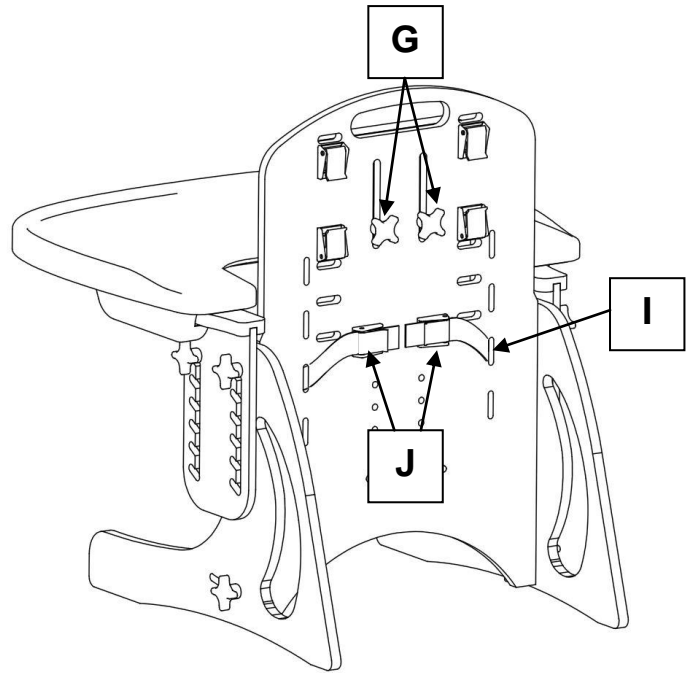

5.3 ARM REST ADJUSTMENT

To raise or lower the arm rests – each can be independently set.

- Loosen the handwheels (H)
- Adjust the arm rest to the desired height
- Retighten the handwheels (H), ensuring they are sufficiently tight prior to use

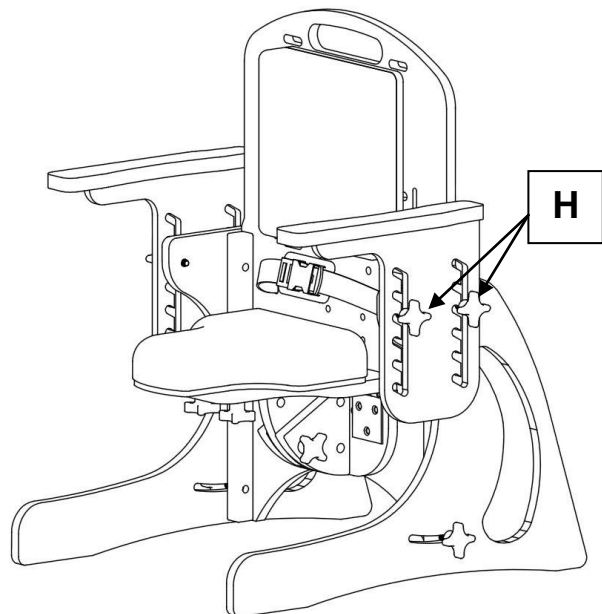

5.4 POSITIONING STRAPS

5.4.1 PELVIC STRAP

- Position the strap through the desired pair of vertical slots (I). There are four heights available. Feed the strap ends through the cam locks provided (J)
- Ensure the strap is firmly fastened across the hip to hold the child safely and in the correct position
- The buckle is secured by pushing (K) into (L)
- To release the buckle, press both sides of (K), as shown

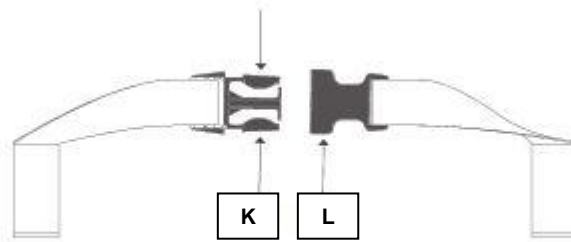

5.4.2 CHEST HARNESS

- The chest harness is fitted to the chair through four horizontal slots (M)
- There are three height positions available
- Feed the strap ends through the four cam locks provided on the rear of the chair (N)
- Note that when the back cushion is set to its highest setting, the top chest harness straps should pass over the back wood **rather** than through the two top slots (see below right)

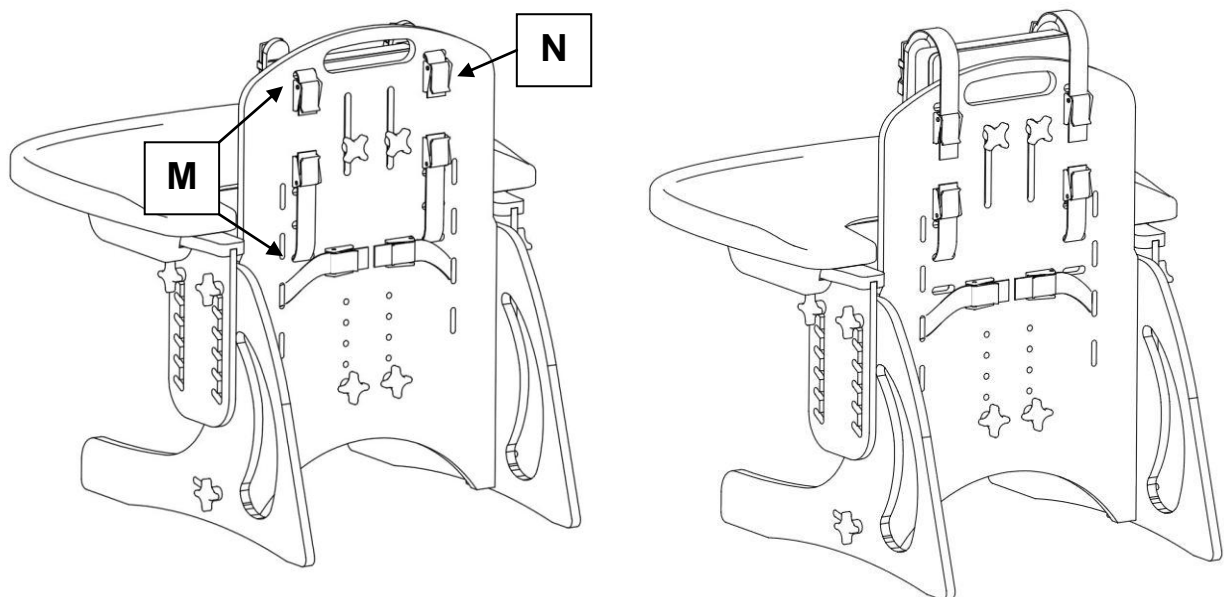

5.5 TRAYS

5.5.1 WOODEN TRAY

- Before fitting the wooden tray, check to ensure both arm rests are set to the same height (see 5.3)
- Slide tray to the desired position
- Turn the wooden toggles (O) under the tray to secure the tray into position

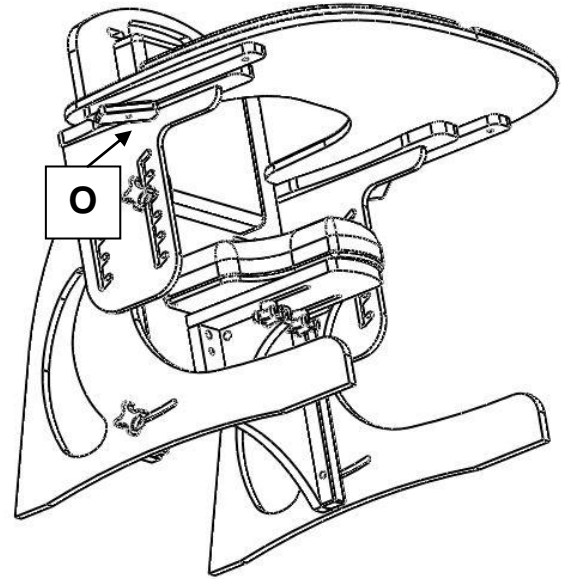

5.5.2 PLASTIC QUICK RELEASE TRAY

- Before fitting the plastic tray, check to ensure both arm rests are set to the same height (see 5.3)
- Slide tray to the desired position
- The tray will lock into position automatically
- To release the tray, pull and hold the handle (P) located underneath the tray (as shown below) and then slide the tray toward you

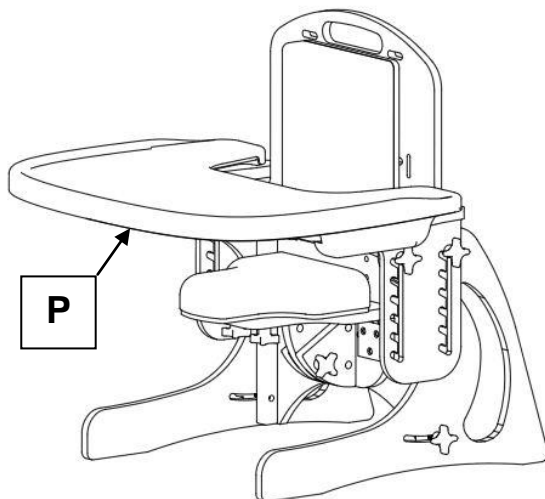

UNDERSIDE OF TRAY
SHOWN

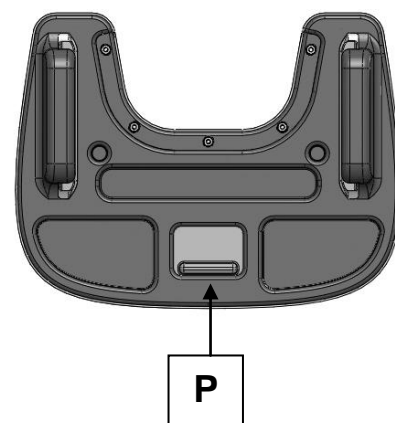

6.0 CARE AND MAINTENANCE

! CAUTION

CLEANING IS RECOMMENDED ON A REGULAR BASIS.

- Clean upholstery and wooden parts with a damp cloth and mild detergent.
- Stubborn marks on the woodwork should be cleaned by using a soft brush.
- Do not soak or immerse the chair in water.
- The pelvic strap can be cleaned with a damp cloth. In cases of extreme soiling it can be machined washed at low temperature with mild detergent but must be drip dried.
- Store the chair in a cool dry place and out of direct sunlight.
- DO NOT use bleach, solvents, abrasives, synthetic detergents, wax polishes, antibacterial sprays or wipes.
- For further information please refer to MHRA or your NHS cleaning guidelines.

6.1 DAILY CHECKS

- Check the tray (if supplied) to ensure no parts are loose or damaged.
- Check all upholstery for signs of wear and tear.
- Check that the hand wheels tighten correctly, and are not cross-threaded or damaged.
- Check all straps for fraying, and that buckles are not missing/damaged.
- Check all cam locks are present, are securely fixed to the chair, and prevent straps from slipping when pulled.

! CAUTION

THE USER SHOULD NOT BE SEATED WHILE THE CHECKS ARE CARRIED OUT.

6.2 SERVICE INTERVAL

The Portable Hip Spica chair should be serviced every 3 years. Servicing must only be undertaken by a Smirthwaite service engineer, or by a Smirthwaite trained representative.

7.0 GUARANTEE & SERVICE

The chair is issued with a full parts and labour guarantee for 2 years from the date of delivery. This guarantee does not apply to accidental damage caused through inappropriate use of the chair. This guarantee is issued at the discretion of G&S Smirthwaite Ltd on RTB (Return to Base) basis. If you have any questions or doubts relating to the safety or use of the chair please contact us for advice or assistance on:

T: +44 (0) 1626 835552

E: info@smirthwaite.co.uk

8.0 CONTINUOUS IMPROVEMENT

G&S Smirthwaite Ltd are committed to continuous improvement to their product range. Should you have any suggestions or comments please send them to our product design department at: info@smirthwaite.co.uk

G&S Smirthwaite Ltd reserve the right to change the specification or material without prior notice.

For catalogues, help and further information on our products please contact us at:

G&S Smirthwaite Ltd
17 Wentworth Road
Heathfield
Devon.TQ12 6TL

T: +44 (0) 1626 835552

F: +44 (0) 1626 835428

E: info@smirthwaite.co.uk

W: www.smirthwaite.co.uk



G&S Smirthwaite, 17 Wentworth Road, Heathfield, Newton Abbot, Devon.TQ12 6TL
T: +44 (0) 1626 835552 F: +44 (0) 1626 835428 E: info@smirthwaite.co.uk
W: www.smirthwaite.co.uk