

Whirl

INSTRUCTIONS FOR USE

Codes 8351-8354



CONTENTS	PAGE
1.0 INTRODUCTION	1
2.0 ILLUSTRATION OF YOUR WHIRL	2
3.0 FOR YOUR SAFETY	2
4.0 SETTING UP YOUR STANDER	3
5.0 ADJUSTING YOUR STANDER	3-7
6.0 TRANSFER	8
7.0 CARE AND MAINTENANCE	9
8.0 GUARANTEE AND SERVICE	9
9.0 CONTINUOUS IMPROVEMENT	10
10.0 WARRANTY AND AFTER SALES	11

1.0 INTRODUCTION

Thank you for choosing your new Smirthwaite Whirl Stander.

The Whirl has been designed to give excellent symmetry and enable children from a young age to gradually develop and maintain their ability to weight bear. It is suitable for children who require minimal to high levels of support and control.

Heights & weights of the Whirl are shown below:

SIZE	USER HEIGHT* – CM	MAX CHILD WEIGHT – KG
1	63-102	70
2	76-127	90

*Measured from footplate to Thoracic support (top)

IMPORTANT!

These instructions should be read by all therapists and carers before using the equipment and should be retained for future reference.

The Whirl requires an assessment to establish goals and benefits as part of the user's therapy programme and should always be used under professional guidance.

Any incorrect use of the product and failure to follow the instructions may put the user at risk or impede the function. If you have any queries using this product or wish for further copies of this IFU please do not hesitate to contact Customer Service department on T: +44 (0) 1626 835552.

2.0 ILLUSTRATION OF YOUR WHIRL STANDER

- A. Padded thoracic support
- B. Padded pelvic support
- C. Activity tray and bowl
- D. Knee cups
- E. Mechanical angle adjustor*
- F. Indexable footrests

*An electric actuator version is also available.

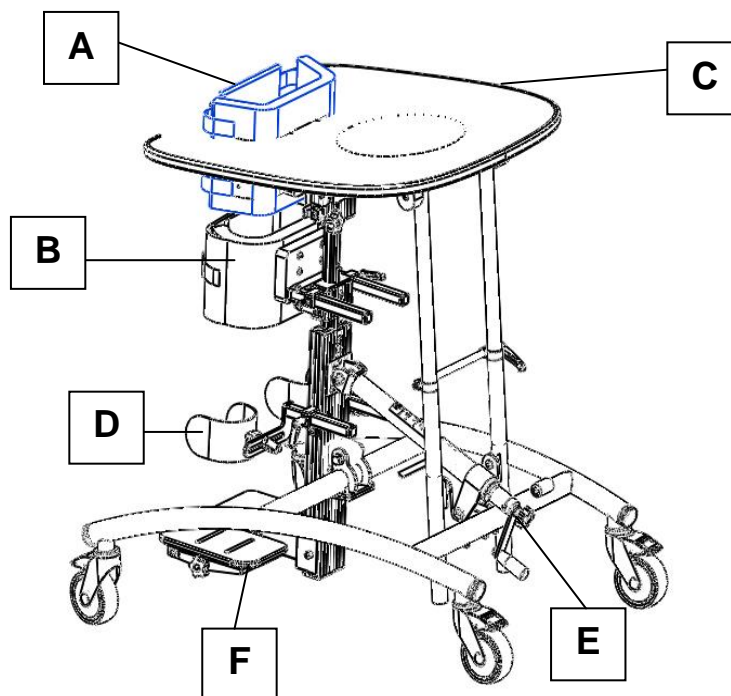

3.0 FOR YOUR SAFETY

PLEASE READ THESE INSTRUCTIONS BEFORE MAKING ANY ADJUSTMENTS.

- The user should NOT be left unattended whilst using the Whirl. Always ensure a responsible adult or carer is in attendance.
- Regular maintenance checks and cleaning are essential for the safe use of this equipment (see care and maintenance section).
- Use only on a flat surface and do not exceed the axilla heights or weight limits specified above.
- If any part is loose, damaged or functioning incorrectly, do not use until rectified.
- Check that all 4 castor brakes are locked and all parts are secure before the user is transferred to the stander.
- The Whirl is supplied fully assembled except for the tray. Check before use that all parts are present and undamaged. Please read the instructions below carefully to ensure safe usage.

4.0 SETTING UP YOUR STANDER



PLEASE NOTE

ALWAYS TURN LEVER LOCKS, HANDWHEELS AND SCREWS CLOCKWISE TO TIGHTEN OR ANTI-CLOCKWISE TO LOOSEN.

Set up is made safer and easier by following the instructions below.

- Ensure all 4 castors are brake locked.
- Remove the activity tray.
- Take the intended user's measurements.
- Set the stander up approximately to these measurements and make final adjustments when the user is in place.

Smirthwaite offer, at no extra charge, an appointment with a product specialist who will assist in the initial product set up.

5.0 ADJUSTING YOUR STANDER



PLEASE NOTE

Provided with your Whirl you will find a 4mm and 6mm Hexagon key. This is for use to help adjust your stander.

5.1 MAIN COLUMN HEIGHT

- The main column height can be adjusted by loosening screw (A) with the 6mm hexagon key provided.
- Slide the inner column to the desired height and refasten (A) securely.
- The inner column is prevented from being removed completely by a mechanical stop mechanism.

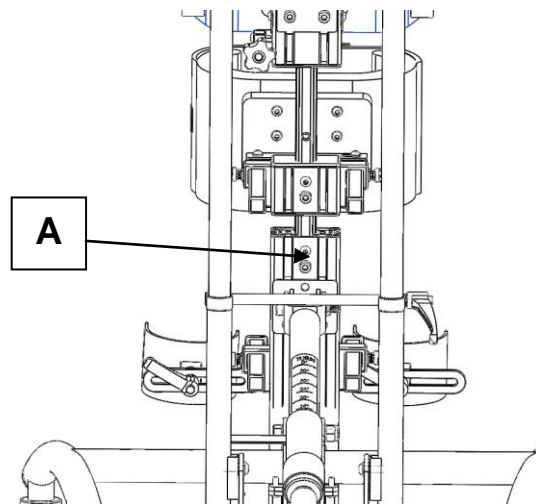

5.2 KNEE BLOCK ADJUSTMENT

Depth (Flexion / Extension)

- Loosen the lever lock (B).
- Slide the knee block through the clamp to the desired depth.
- Retighten the lever lock (B).

Height

- Loosen screw (C) with the 6mm hexagon key.
- Slide the clamp to the desired height.
- Retighten the screw (C).

Lateral (Adduction/Abduction) Position

- Loosen the lever lock (D).
- Slide the knee block to the desired position, ensuring maximum contact is made.
- Retighten the lever lock (D).
- Repeat for the second knee block .
- By loosening the lever lock (D), it is also possible to swivel the knee block to the desired position.
- Repeat for second knee block.

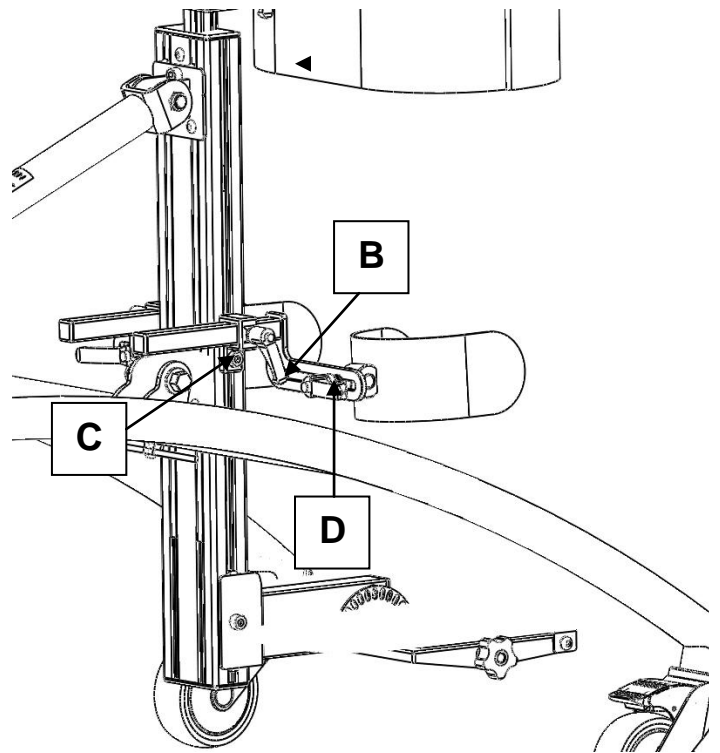

5.3 PELVIC SUPPORT

Height

- Loosen the 6mm screw (G).
- Slide the pelvic support section to desired height.
- Retighten the 6mm screw (G).

Depth

- Loosen both lever locks (H).
- Adjust the depth of the pelvic support to the desired position.
- Retighten both level locks (H).

Rotation

- Rotation of the pelvic support can be achieved by independently loosening lever locks (H) and adjusting each to suit.
- Retightened lever locks (H) when finished.

Width

- Loosen 4 screws (I) using the hexagonal driver.
- Slide the aluminum plates to the desired position.
- Retighten 4 screws (I) to lock into position.

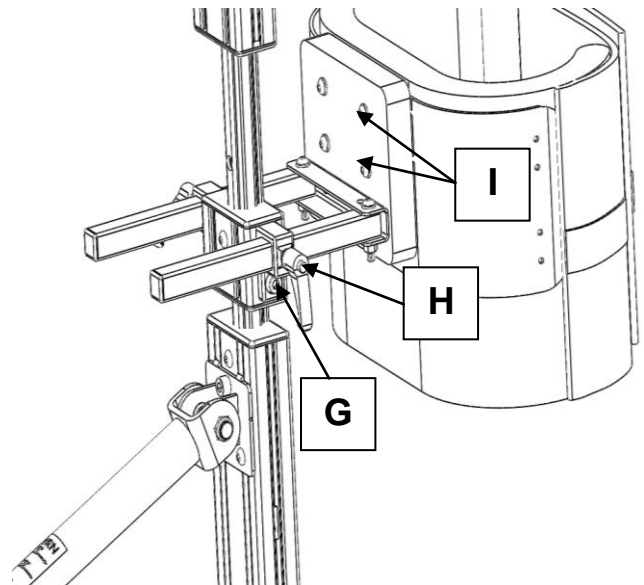

5.4 THORACIC SUPPORT

Width

- Loosen 4 screws (K) using the hexagonal driver.
- Slide the aluminum sides to the desired width.
- Retighten the 4 screws (K).

Fine Height

- The wooden block (L) on the rear of the thoracic support has two screws that, when loosened, permit the movement of the thoracic support through a fine range upwards and downwards.
- Ensure the screws are fastened tight once the desired height is achieved.

Angle

- Rotate hand wheel (M) to give the desired angle.

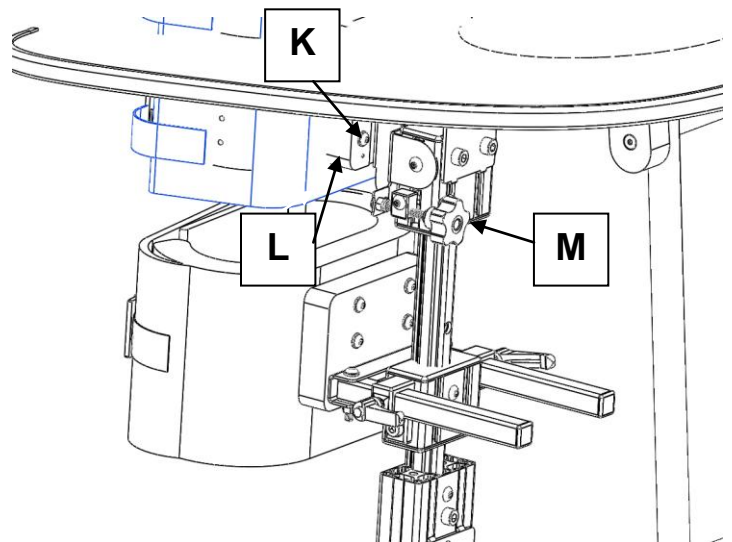

5.5 TRAY

Height

- Loosen lever lock (N).
- Lift tray to the desired height.
- Retighten level lock (N).
- Loosen 2 screws (P) using the hexagonal driver. This permits further tray height adjustment.
- Ensure screws (P) are secured when desired height is set.

Release

- To release the tray from the main column assembly, pull both plunger pins (O) and lift tray.
- When replacing the tray into position, ensure the plunger pins are securing engaged.

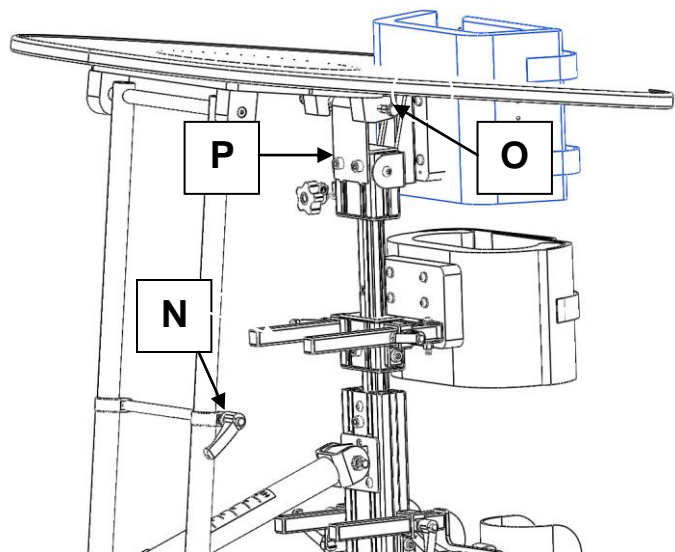

5.6 COLUMN ANGLE ADJUSTMENT (MECHANICAL)

Angle Adjustment

- Ensure hand wheel (Q) is tight to engage the drive.
- Rotate handle (R) until desired angle is achieved.
- Disengage hand wheel (Q) to ensure the angle adjustment is secure.

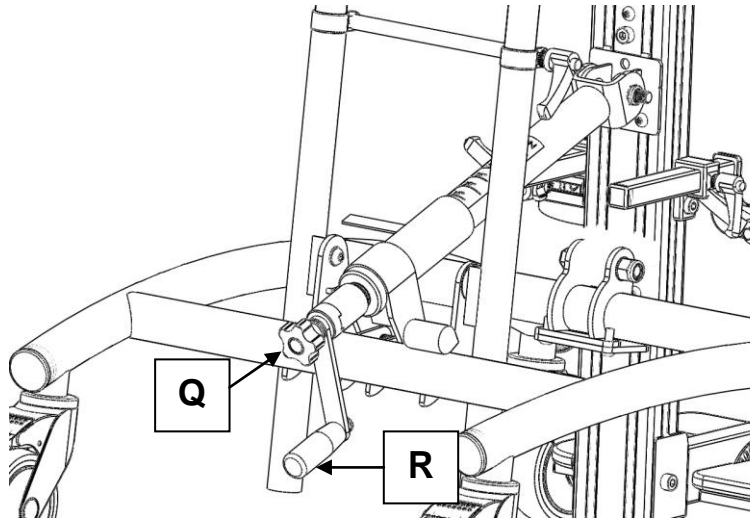

5.7 COLUMN ANGLE ADJUSTMENT (ELECTRIC)

Angle Adjustment

- The electric Whirl variant is fitted with a battery pack, actuator (S) and handset/controller (T).
- Press the Up or Down arrow on the handset to adjust stander to the desired angle.

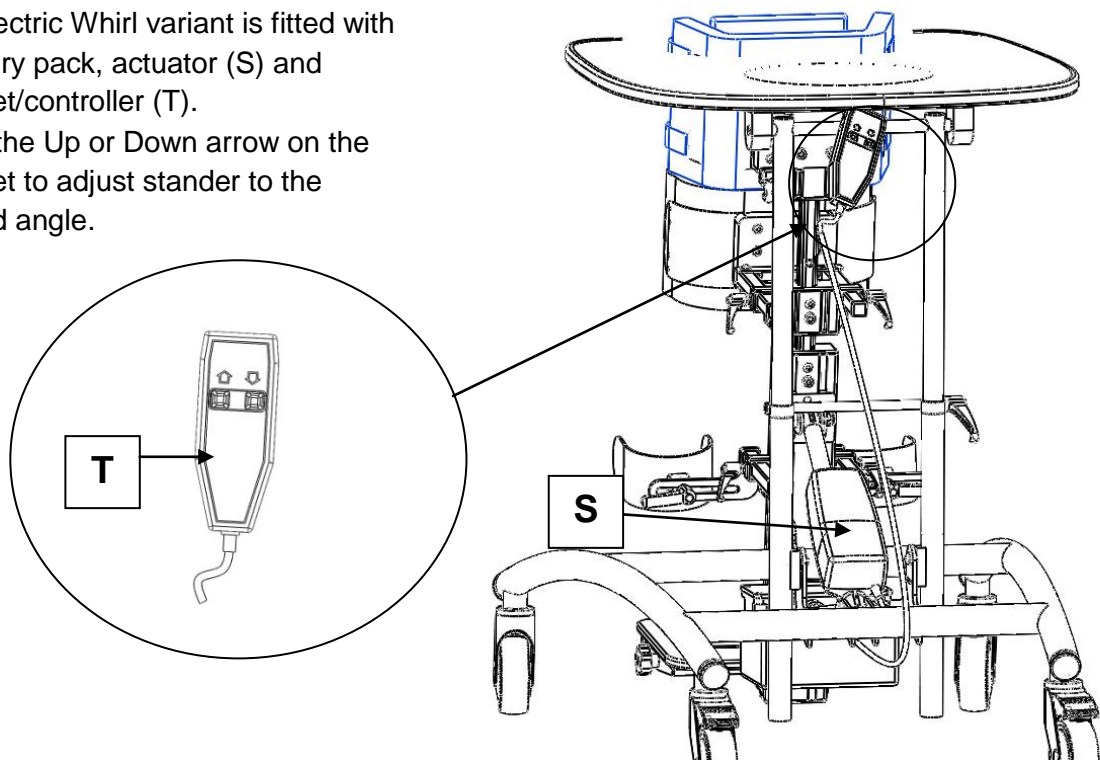

5.8 BATTERY AND SAFETY CUT OUT

Battery Care

- Charge the battery 24 hours before use.
- Keep the battery fully charged.
- Charge once a week, overnight for instance
- To charge, plug the charging unit into the mains - ensure the red stop button is released.
- Connect its lead to the handset (U).
- Ensure the handset is connector to the control box/battery.
- To cut the power in case of emergency, simply push the red stop button (V).
- Ensure the red emergency stop (V) is twisted out.

Note:

- The red stop button is used in case of emergency; do not use as an on/off switch.
- Twist the red button clockwise to reset.
- If the battery becomes discharged to a critical level, a warning tone will sound. Charge the battery as soon as this tone is heard.
- Batteries should be replaced at least every 4 years.

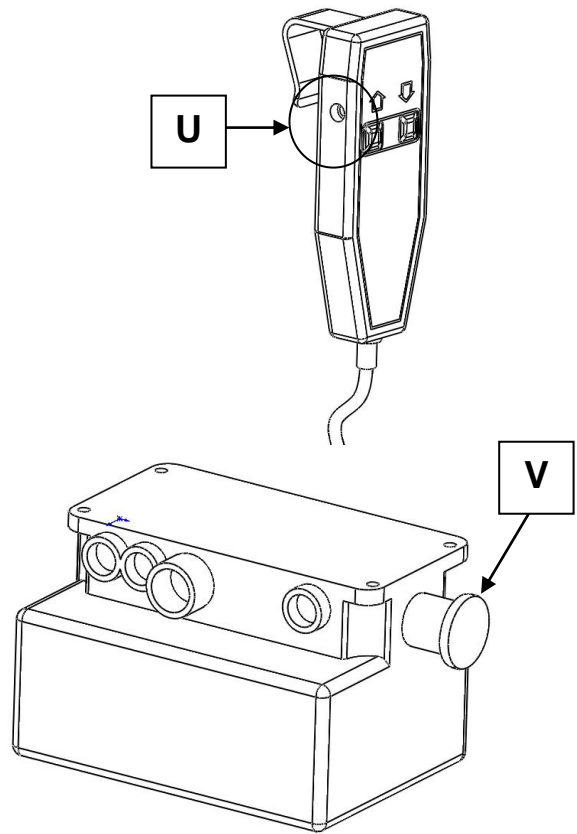

5.9 INDEXING FOOT RESTS

Angle Adjustment

- Accurate foot placement can be achieved by making incremental adjustments of **each** foot rest.
- Loosen the locking hand wheel (W) on the foot rest.
- Pull the footrest outward slightly and rotate to the desired angle, using the stopper pin as a guide (X).
- When the desired position is achieved, simply lock the footrest securely by retightening the hand wheel (W).

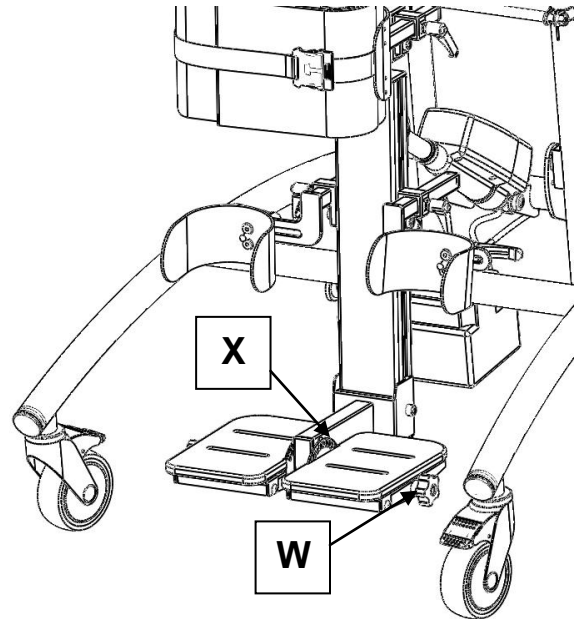

6.0 TRANSFER

- Open all the straps on the Thoracic Support, Pelvic Support and Sandals.
- Unlock the castors and move the Whirl in front of the seated child.
- Lock the 4 castors at 45° to each other.
- Release the catch located under each footrest and lift upwards, towards the child's feet.
- Secure the child's feet in the sandals, using the straps provided.
- The child may then be carefully positioned vertically into the stander.
- Support the child, whilst securing the straps on the Thoracic Support and Pelvic Support.
- Make adjustments to the Thoracic, Pelvic and Knee support as needed.
- Follow the adjustment instructions as needed.

7.0 CARE AND MAINTENANCE

! CAUTION

CLEANING IS RECOMMENDED ON A REGULAR BASIS

- Clean upholstery and wooden parts with a damp cloth and mild detergent.
- Make sure brakes are released before moving.
- Store the stander in a cool dry place and out of direct sunlight.
- Anti-bacterial wipes may be used to clean the Whirl Tray.
- For further information please refer to MHRA or NHS cleaning guidelines.

! CAUTION

REGULAR MAINTENANCE CHECKS ARE RECOMMENDED. THE USER SHOULD NOT BE IN THE STANDER WHILE THE CHECKS ARE CARRIED OUT.

DAILY & MONTHLY CHECKS

- Check the product for damage or loose components.
- Check the structure of the product for signs of damage wear and tear.
- Keep all parts clean.

7.1 SERVICE INTERVAL

The Whirl should be serviced every 1 year. Servicing must only be undertaken by a Smirthwaite service engineer, or by a Smirthwaite trained representative.

8.0 GUARANTEE & SERVICE

The Whirl stander is issued with a full parts and labour guarantee for 2 years from the date of delivery. This guarantee does not apply to accidental damage caused through inappropriate use of the product. This guarantee is issued at the discretion of G&S Smirthwaite Ltd on RTB (Return to Base) basis. If you have any questions or doubts relating to the safety or use of the product please contact us for advice or assistance on:

T: +44 (0) 1626 835552

E: info@smirthwaite.co.uk.

NO ADAPTATIONS OR ALTERATIONS SHOULD BE MADE TO THE WHIRL PRONE STANDING FRAME WITHOUT WRITTEN AUTHORISATION BY SMIRTHWAITE; ANY SUCH MODIFICATION WILL AFFECT THE GUARANTEE.

9.0 CONTINUOUS IMPROVEMENT

G&S Smirthwaite Ltd are committed to continuous improvement to their product range. Should you have any suggestions or comments please send them to our product design department at: info@smirthwaite.co.uk.

G&S Smirthwaite Ltd reserve the right to change the specification or material without prior notice.

For catalogues, help and further information on our products please contact us at:

G&S Smirthwaite Ltd
17 Wentworth Road
Heathfield
Devon TQ12 6TL

T: +44(0) 1626 835552

F: +44(0) 1626 835428

E: info@smirthwaite.co.uk

W: www.smirthwaite.co.uk



G&S Smirthwaite, 17 Wentworth Road, Heathfield, Newton Abbot, Devon.TQ12 6TL
T: +44 (0) 1626 835552 F: +44 (0) 1626 835428 E: info@smirthwaite.co.uk
W: www.smirthwaite.co.uk