

THE COMPLETE CHANGING AND SHOWERING RANGE IN ONE PLACE



easi-change



MOBI
HI-RISER
EASI-LIFT
EASI-SHOWER





WELCOME TO THE WORLD OF EASI-CHANGE.

Easi-Change manufactures practical and economical solutions for changing and showering. When children or adults are unable to change or wash independently more supportive equipment is often required. Designed to be comfortable and hygienic for the user and easy to use for the carer, you will find an Easi-Change wall mounted or mobile, showering or changing solution to meet your needs.

Easi Support

Easi-Change has a large number of experienced local distributors both inside the UK and internationally who can personally advise on our range of products. Their services includes site visits, consultation and installation of the most practically appropriate equipment to suit the intended environment and the needs of both the user and the carer.

Easi to Use

Easi-Change designs and manufactures well-made, easy to use products that stand the test of time. Through close consultation with therapists and users, the practical, no-fuss range of Easi-Change products have evolved, giving confidence to both the specifier and the user. All Easi-Change products come with a Manufacturer's 2-year warranty.

Easi to Specify

Our trusted network of distributors are authorised to supply Easi-Change products. Please contact us directly and we will connect you to your nearest Easi-Change distributor.

Website: www.easi-change.co.uk

Telephone: 0845 519 2121

E-mail: info@easi-change.co.uk

CONTENTS

Mobi range:

- 3 Mobi changer
- 5 Mobi heavy duty changer
- 7 Mobi shower trolley

Hi-riser range:

- 9 Hi-riser
- 11 Hi-riser shower stretcher

Easi-lift range:

- 13 Easi-lift changing bench
- 15 Easi-lift shower stretcher

Easi-shower range:

- 17 Shower stretcher fixed height
- 19 Shower stretcher adjustable height

Product	Changing	Showering	Travel Range	Length	Width	User Weight
Mobi range						
Mobi changer	✓		470mm - 950mm	1400mm, 1600mm & 1800mm	750mm	227kg
Mobi heavy duty changer	✓		550mm - 920mm	2000mm	960mm	450kg
Mobi shower trolley	✓	✓	465mm - 925mm	1800mm	750mm	220kg
Hi-riser range						
Hi-riser powder coated	✓		400mm - 1000mm	1200mm - 1800mm	550mm - 650mm	200kg
Hi-riser stainless steel	✓	✓	400mm - 1000mm	1200mm - 1800mm	550mm - 650mm	200kg
Hi-riser shower stretcher	✓	✓	390mm - 960mm	1400mm & 1800mm	650mm	150kg
Easi-lift range						
Easi-lift changing bench	✓		450mm - 950mm	1200mm - 1700mm	550mm - 650mm	150kg
Easi-lift shower stretcher	✓	✓	450mm - 950mm*	1400mm, 1500mm, 1600mm, 1700mm, 1800mm & 1900mm	650mm	200kg
Easi-shower range						
Shower stretcher fixed height	✓	✓	Fixed	1400mm, 1500mm, 1600mm, 1700mm, 1800mm & 1900mm	650mm	200kg
Shower stretcher adjustable height	✓	✓	450mm - 800mm*	1400mm, 1500mm, 1600mm, 1700mm, 1800mm & 1900mm	650mm	200kg

*dependant on installed height

Colour range
See back of
catalogue



This image shows the product
in a stainless steel option

Product is shown with the angled back,
please see page 21



This image shows the product
in a powder coated option

The Mobi range Mobi changer

(powder coated for dry rooms and stainless steel for bath/changing rooms)

Room to room

The Mobi changer is a fully mobile changing table that requires no installation or fixing. Its compact and slimline design means it can be easily manoeuvred from room to room, offering an extremely cost effective option for multi-transfer or multi-user environments.

Height adjustable

The electrically operated Mobi changer provides an excellent travel range of 480mm and can be lowered and elevated at the touch of a button. Safe and suitable working heights can be easily achieved which helps prevent the risk of back injury to the carer.

Easy transfers

The Mobi changer has been designed to ensure sufficient clearance for a wide number of hoists. Its mobility and unique stowaway side rails enable safe and easy handling. Whether you are transferring from a bed, wheelchair or toileting chair, the Mobi changer is the perfect solution.

Charger features

The Mobi changer will be supplied with a wall mounted charger and 2 batteries as standard.

Safety skirt

The Mobi changer has an innovative protective skirt to prevent any contact with the powered lifting mechanism, ensuring the carer can always work safely.

KEY FEATURES

- Mobile and easy to manoeuvre
- No installation required
- Cream powder coated frame for dry room environments
- Stainless steel for damp room environment i.e. bath/changing room
- Available in 3 sizes
- Length of table available in 1400mm, 1600mm or 1800mm
- Weight capacity of 227kg
- Travel range of 480mm
- Easy to clean padded surfaces
- Optional angled back (please see page 21 for more details)
- Unique stowaway side rails

Mild Steel Powder Coated	Stainless Steel	Size	User Weight	Table Dimensions		Travel Range	Safety Sides		Safety Sides Operational Space	Castor Centres	Nominal Clearances	Shipping Weights	
				kg	L mm		W mm	H mm					Width X mm
3121	3141	1	227	1400	750	470 - 950	840	165	200	1090	700	190	86
3122	3142	2	227	1600	750	470 - 950	840	165	200	1090	700	190	88
3123	3143	3	227	1800	750	470 - 950	840	165	200	1090	700	190	90

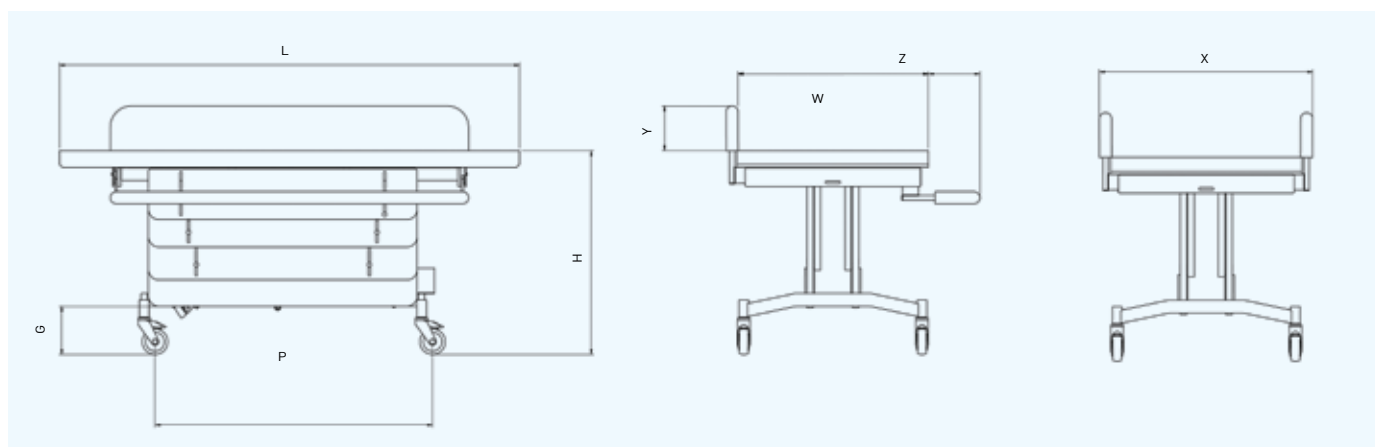

Colour range
See back of
catalogue



The Mobi range

Mobi heavy duty changer

Meeting bariatric needs

The Mobi heavy duty changer has been designed to meet the needs of bariatric users. Its powerful 12K Newton motor, coupled with the extra wide mattress platform, makes it the ideal solution.

Extra support

It is imperative that the user is comfortable whilst being changed. The extra thick layer of cushioning foam ensures comfort throughout use.

Manoeuvrability

The benefit of the Mobi range of products is that they do not require any wall mounting or floor fixing. They are easy to manoeuvre which means that the user can be transported from room to room with no trouble (door opening has to be 1100mm or more).

No fuss

The Mobi heavy duty changer is electronically operated, which makes adjusting the height of the table simple.

KEY FEATURES

- Mobile and easy to manoeuvre
- No installation required
- Electronically operated
- Cream powder coated frame for dry room environment only
- Length of table available in 2000mm
- Weight capacity of 450kg
- Travel range of 370mm
- Easy to clean padded surfaces
- Unique stowaway side rails
- Wall mounted charger and 2 batteries as standard

Mild Steel Powder Coated	Size	User Weight	Table Dimensions		Travel Range	Safety Sides		Safety Sides Operational Space	Castor Centres		Nominal Clearances	Shipping Weights
			L mm	W mm		H mm	Width X mm		Height Y mm	Z mm		
3161	1	450	2000	960	550 - 920	1050	165	200	1500	800	150	100

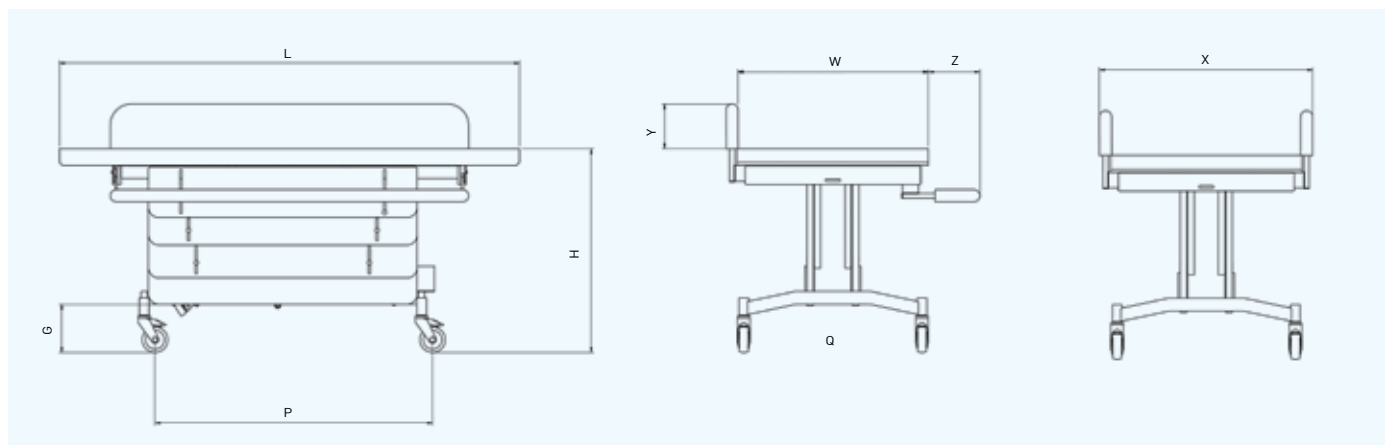

Colour range



The Mobi range

Mobi shower trolley

Safe showering

For many children and adults, conventional methods of bathing and showering can be difficult and even hazardous. The Mobi shower trolley is a powered, height-adjustable shower trolley specifically designed to enable the user to be safely and easily washed or showered by their carer.

Reduces back injury

The Mobi shower trolley offers a range of height adjustments to enable the carer to shower and change the user at a safe and suitable working height. This reduces the risk of back injury for the carer.

Easy to manoeuvre

Mobile and easy to manoeuvre, the Mobi shower trolley can be easily wheeled to and from any room, making it an ideal bathing solution for a wide range of care settings. Four locking castors prevent movement during transfer.

Stowaway side rails

The Mobi shower trolley has been designed with two unique safety side rails that can be easily stowed away beneath the trolley. This allows maximum clearance for safe, easy transfer and use.

Charger Features

The Mobi shower trolley will be supplied with a wall mounted charger and 2 batteries as standard.

KEY FEATURES

- Mobile and easy to manoeuvre
- No installation required
- Stainless steel frame
- Drainage channel and pipe
- Soft comfortable mattress and wedge shaped pillow
- Available in 1 size
- Length of table is 1800mm
- Weight capacity of 220kg
- Travel range of 460mm
- Easy to clean padded surfaces
- Unique stowaway side rails
- Optional padded mattress as an accessory

Stainless Steel	Size	User Weight kg	Table Dimensions		Travel Range H mm	Safety Sides		Safety Sides Operational Space Z mm	Castor Centres		Nominal Clearances G mm	Shipping Weights kg
			L mm	W mm		Width X mm	Height Y mm		P mm	Q mm		
3151	1	220	1800	750	465 - 925	840	195	200	1090	700	190	86

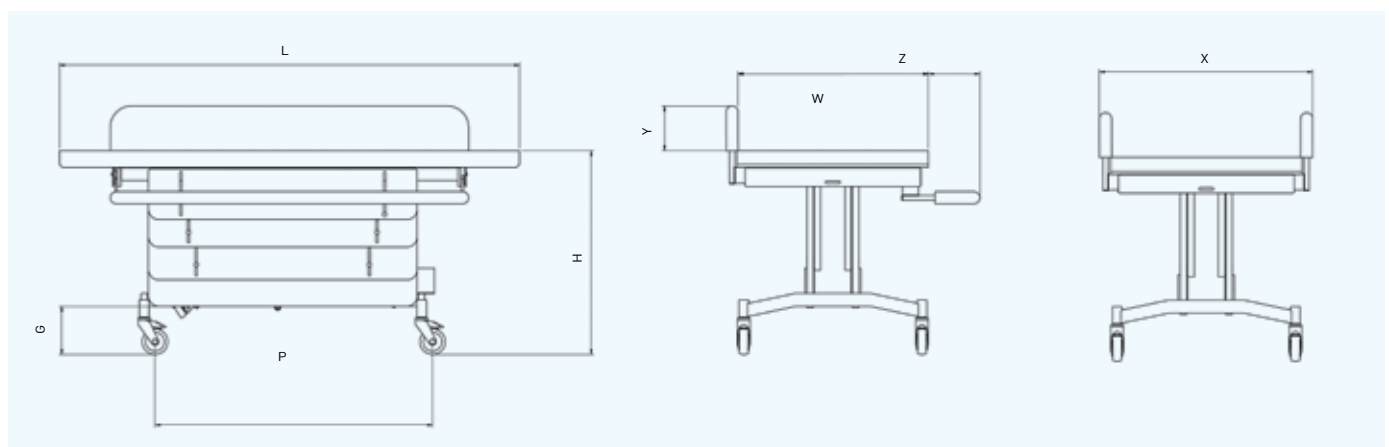

Colour range
See back of
catalogue



The Hi-riser range

Hi-riser

(powder coated for dry rooms and stainless steel for bath/changing rooms)

Robust yet slimline

Hi-riser is an electrically operated wall-mounted changing table that is suitable for children and adults of up to 200kg. Despite its robust structure, the Hi-riser has a slimline design that ensures it fits easily into most environments.

Sizes to suit

We understand that every need is different, which is why the Hi-riser comes in seven different sizes that cater from young children through to adults.

Easy transfer

The Hi-riser has been designed so that it can be used with most mobile or ceiling hoists. The unique safety side rail stows away, streamlining access for transfers from a wheelchair, shower and toileting chair. The Hi-riser also benefits from an impressive travel range of 600mm.

Options

The Hi-riser comes in a cream powder coated frame for dry room environments or stainless steel frame for damp room environments for example bath rooms.

KEY FEATURES

- Electrically operated
- Wall and floor mounted
- Cream powder coated frame for dry room environments.
- Stainless steel for damp room environment i.e. bath/changing room
- Available in 7 sizes
- Length of table available in 100mm increments from 1200mm – 1800mm
- Weight capacity of 200kg
- Impressive height range of 600mm
- Folds away to save on space
- Easy to clean padded surfaces

Mild Steel Powder Coated	Stainless Steel	Size	User Weight kg	Table Dimensions			Travel Range H mm	Wall Frame Width A mm	Wall Frame Depth B mm	Wall Frame Height C mm	Safety Side Height Y mm	Stored Width S mm	Shipping Weight kg
				L mm	W mm	M mm							
3041	3051	1	200	1200	550	875	400 - 1000	700	110	1550	165	305	80
3042	3052	2	200	1300	550	875	400 - 1000	700	110	1550	165	305	82
3043	3053	3	200	1400	600	925	400 - 1000	700	110	1550	165	305	84
3044	3054	4	200	1500	600	925	400 - 1000	700	110	1550	165	305	86
3045	3055	5	200	1600	650	975	400 - 1000	700	110	1550	165	305	88
3046	3056	6	200	1700	650	975	400 - 1000	700	110	1550	165	305	90
3047	3057	7	200	1800	650	975	400 - 1000	700	110	1550	165	305	92

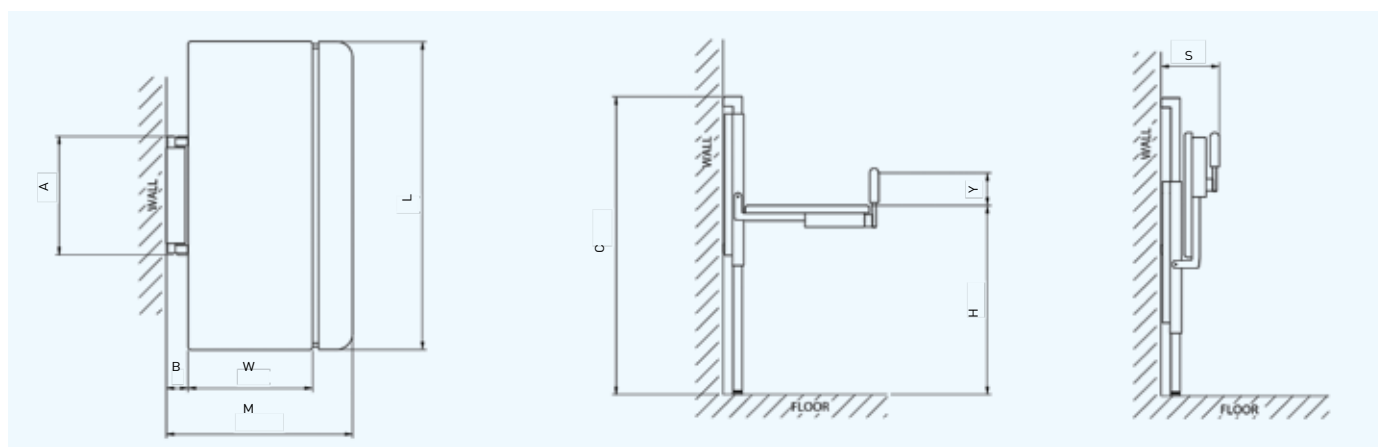

Colour range



The Hi-riser range

Hi-riser shower stretcher

Two-in-one

The Hi-riser shower stretcher is an easy to use two-in-one wall and floor mounted showering and changing table. Its robust yet slimline design makes it suitable for children and adults of up to 150kg. Its versatility means it offers the ideal solution for swimming, hydrotherapy and bathroom environments.

Comfortable & hygienic

The Hi-riser shower stretcher has been designed with reinforced PVC, making it highly supportive yet soft and comfortable to lie on. Its stainless steel frame facilitates easy cleaning, making it a perfect choice for multi-user environments.

Quick drainage

The Hi-riser shower stretcher is supplied with flexible pipe work to use with a suitable floor drain or, alternatively, it can be plumbed in. Water can easily be drained away using the drainage pipe, which can also be detached for cleaning purposes.

Options

The Hi-riser shower stretcher is available in two sizes and comes complete with a padded safety rail.

KEY FEATURES

- Electrically operated – handset works safely in wet rooms
- Changing and showering in one
- Drainage pipe and fasteners included
- Wall and floor mounted
- Stainless steel construction
- Available in 2 sizes
- Length of table available in either 1400mm or 1800mm
- Weight capacity of 150kg
- Travel range of 570mm
- Easy to clean padded surfaces
- Unique stowaway side rail
- Folds away to save on space
- Protrudes 300mm from the wall when stored
- Optional padded mattress as an accessory

Stainless Steel	Size	User Weight kg	Table Dimensions			Travel Range H mm	Wall Frame Width A mm	Wall Frame Depth B mm	Wall Frame Height C mm	Safety Side Height Y mm	Stored Width S mm	Shipping Weight kg
			L mm	W mm	M mm							
3063	1	150	1400	650	1110	390 - 960	700	110	1550	165	300	80
3067	2	150	1800	650	1110	390 - 960	700	110	1550	165	300	85

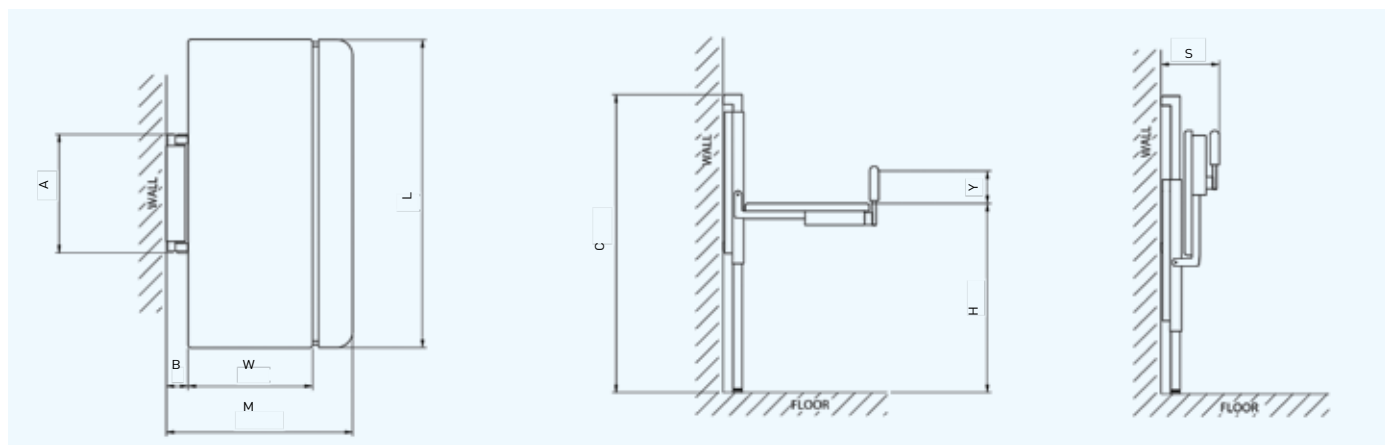

Colour range
See back of
catalogue



Product is shown with the stowaway side rail



The Easi-lift range

Easi-lift changing bench

No floor fixing

Most height-adjustable changing tables require fitting to both the wall and floor. The Easi-lift changing bench has been designed to require wall fixing only. This is particularly beneficial where the type of floor, surface pipe work or cabling prevent floor installation.

Space saving design

Easi-lift changing bench is a compact, electrically operated wall-mounted changing bench designed to fit in a dry room environment where space is at a minimum.

Prevents back injury

The Easi-lift changing bench has a travel range of 500mm to meet varying needs and the bench can easily be set to a safe and suitable working height to help prevent the risk of back injury to the carer.

Stowaway side rail

The Easi-lift changing bench features a unique safety side rail that can be easily stowed away beneath the table. This allows maximum clearance for safe and easy transfer.

KEY FEATURES

- Electrically operated
- No floor fixing required
- Ideal for a dry room environment
- Available in 6 sizes
- Length of table available in 100mm increments from 1200mm – 1700mm
- Weight capacity of 150kg
- Travel range of 500mm
- Folds away to save on space
- Protrudes 305mm from the wall when stored
- Easy to clean padded surfaces

Mild Steel Powder Coated	Size	User Weight kg	Table Dimensions			Travel Range H mm	Wall Frame Width		Wall Frame Height C mm	Safety Side Height Y mm	Stored Width S mm
			L mm	W mm	M mm		A mm	B mm			
3081	1	150	1200	550	875	450 - 950*	700	110	1320	165	305
3082	2	150	1300	550	875	450 - 950*	700	110	1320	165	305
3083	3	150	1400	600	925	450 - 950*	700	110	1320	165	305
3084	4	150	1500	600	925	450 - 950*	700	110	1320	165	305
3085	5	150	1600	650	975	450 - 950*	700	110	1320	165	305
3086	6	150	1700	650	975	450 - 950*	700	110	1320	165	305

*dependant on installed height

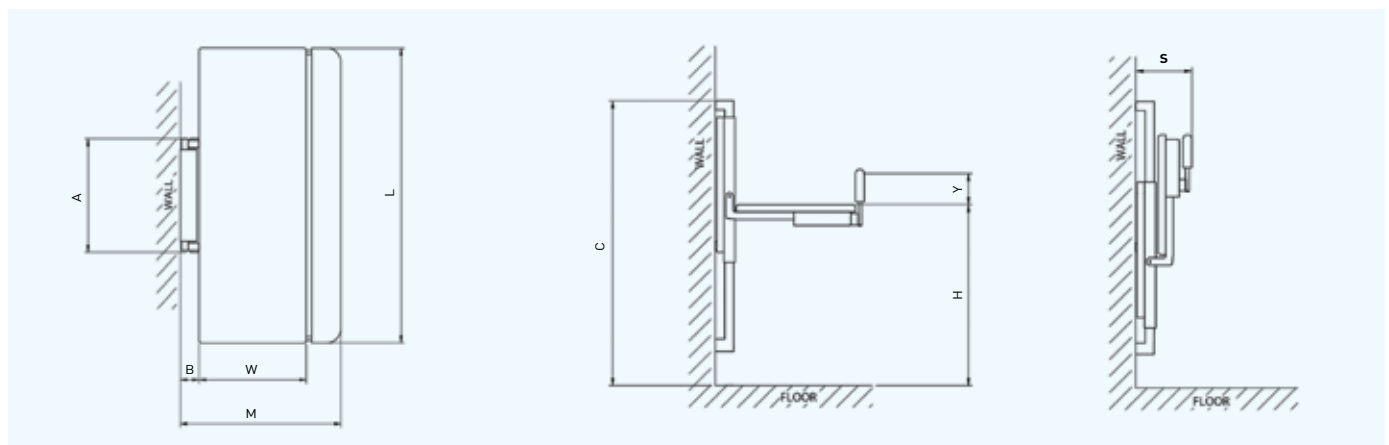

Colour range

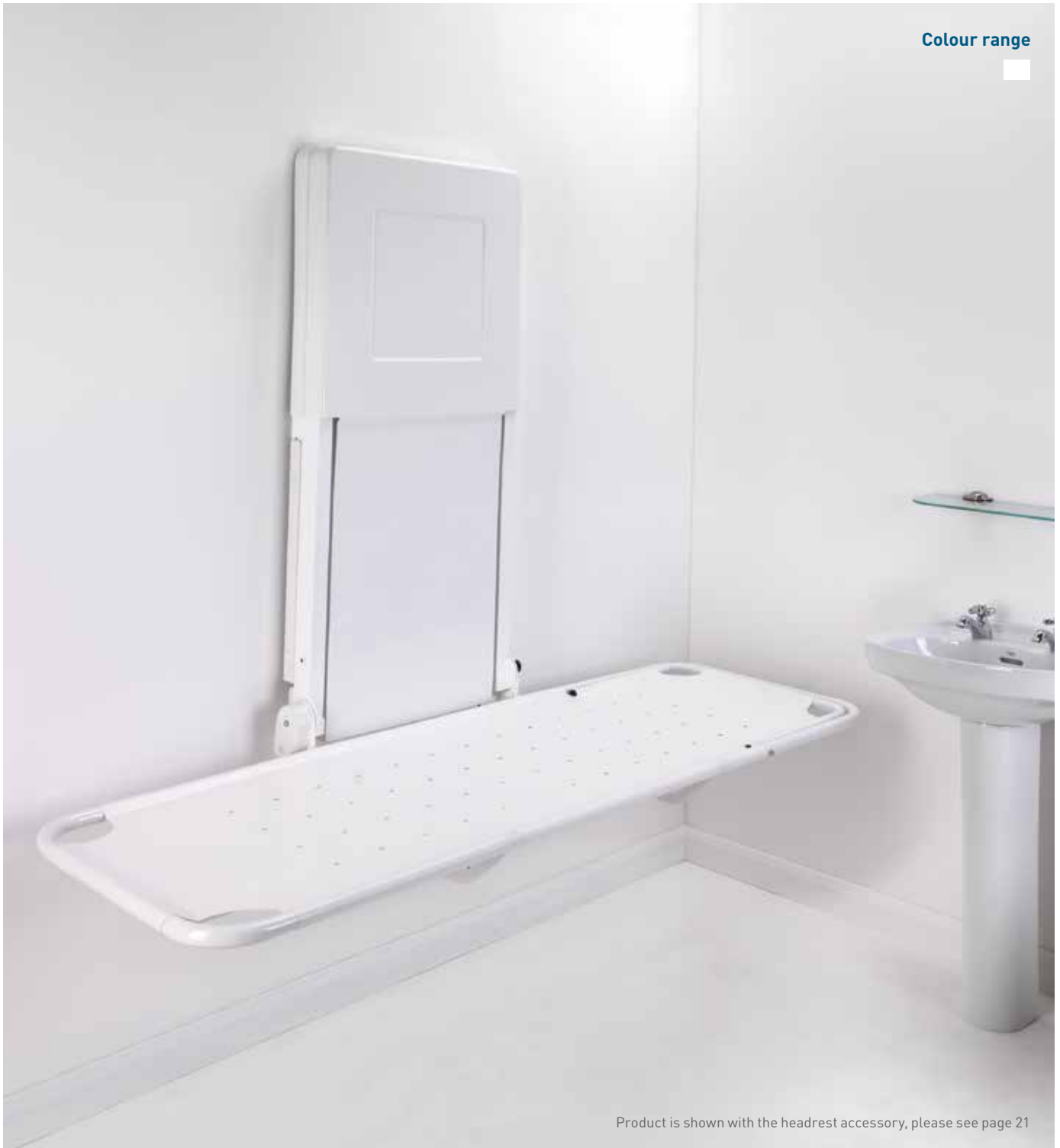

Product is shown with the headrest accessory, please see page 21



The Easi-lift range

Easi-lift shower stretcher

Easy adjustment

The Easi-lift shower stretcher has been designed to help you move the user up and down with ease whilst they are on the stretcher. It is electronically operated with a height range of 500mm, which allows a safe and suitable working height to prevent the risk of back injury to the carer.

Fold away made easy

All of our Easi-lift shower stretchers are fitted with assisted lifting action, which reduces the amount of effort required to fold away the stretcher.

Contemporary design

The unobtrusive and neutral design of the Easi-lift shower stretcher allows it to fit into a wide range of environments. The need for floor fixing has been eliminated making it the perfect choice for areas where the floor type, surface pipe work or cabling prevent floor installation.

Easy storage

The compact design coupled with the ability to fold the stretcher away when it is not in use makes this the ideal product for times when space is limited.

KEY FEATURES

- Electrically operated
- No floor fixing required
- Ideal for a wet room environment
- Stainless steel frame with powder coated finish
- Available in 6 sizes
- Length of stretchers available; 1400mm - 1900mm in 100mm increments
- Weight capacity of 200kg
- Travel range of 500mm
- Folds away to save on space
- Easy to clean surfaces
- Optional integral vinyl headrest
- Optional 1400mm safety guard

Stainless Steel Powder Coated		Size	User Weight kg	Table Dimensions			Travel Range H mm	Wall Frame Width A mm	Wall Frame Depth B mm	Safety Guard Height Y mm	Stored Width S mm
Without Headrest	With Headrest			L mm	W mm	M mm					
3191	3291	1	200	1400	650	1000	450 - 950*	750	110	145**	270
3192	3292	2	200	1500	650	1000	450 - 950*	750	110	145**	270
3193	3293	3	200	1600	650	1000	450 - 950*	750	110	145**	270
3194	3294	4	200	1700	650	1000	450 - 950*	750	110	145**	270
3195	3295	5	200	1800	650	1000	450 - 950*	750	110	145**	270
3196	3296	6	200	1900	650	1000	450 - 950*	750	110	145**	270

*dependant on installed height **safety guard is optional accessory

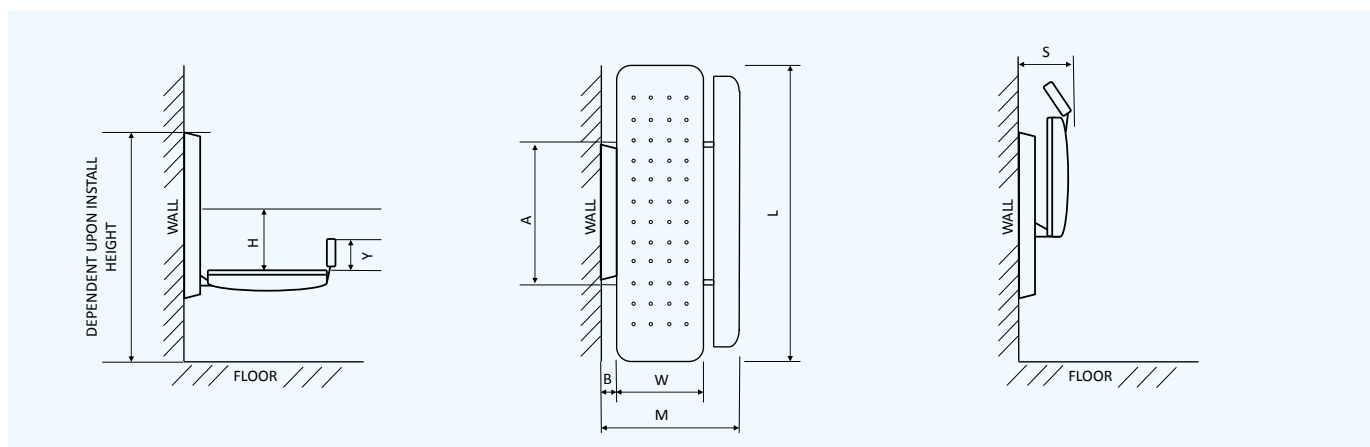

Colour range

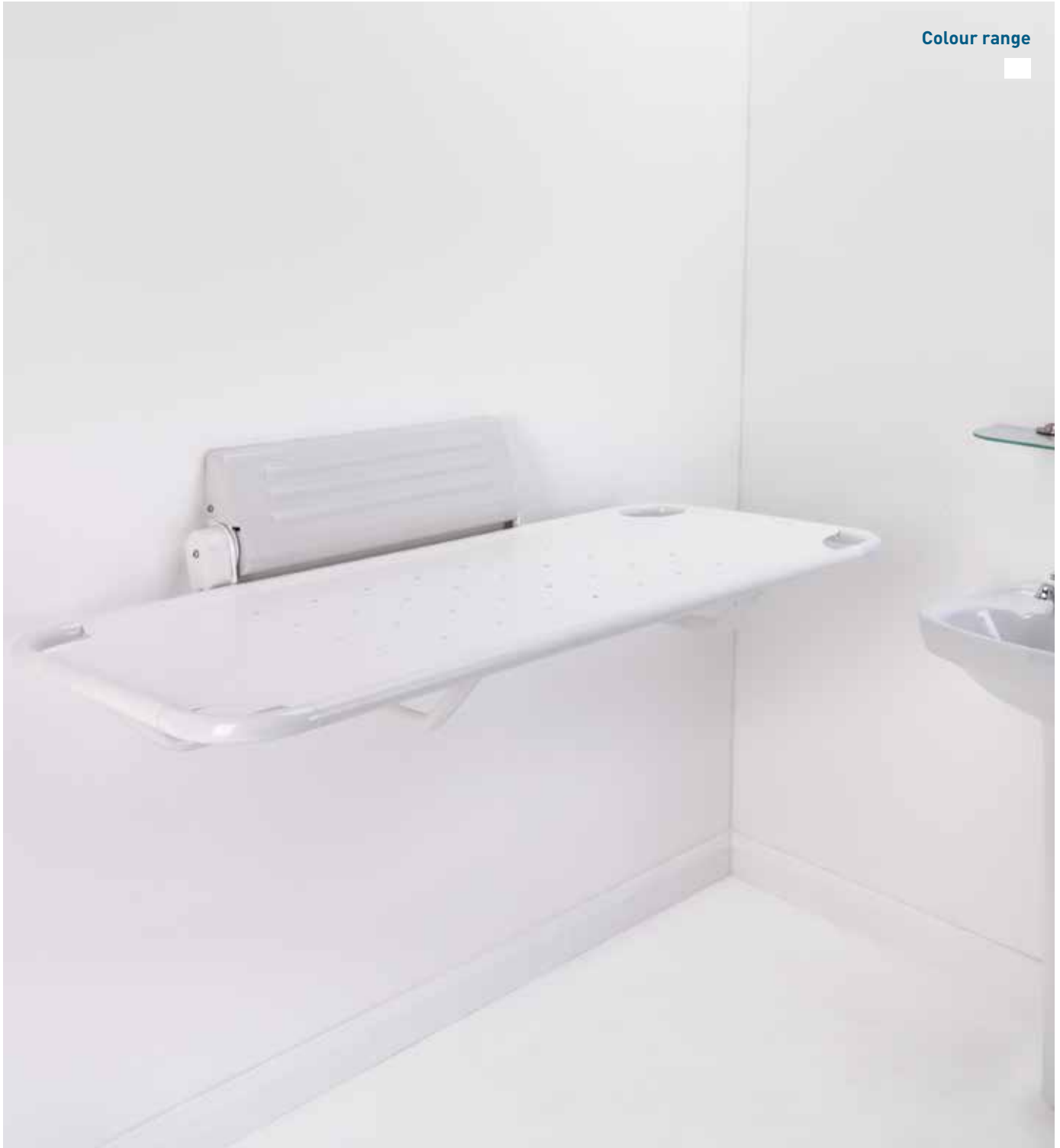

The Easi-shower range

Shower stretcher fixed height

Economical solution

The Shower stretcher fixed height is our entry-level product and an economical washing and showering solution for the user. This durable and slimline product represents real value for money.

Added headrest

The Shower stretcher fixed height, along with all of our shower stretchers, can be enhanced with the optional integral vinyl headrest. The headrest features a paddle lift adjustment, which allows it to be locked securely into the desired position.

For more details please refer to page 21.

Makes bathing easier

The Shower stretcher fixed height is designed to allow the washing or showering of the user whilst in a horizontal position. It can be fixed directly above a bath making it the perfect solution for the home.

Plenty of choice

The Shower stretcher fixed height comes in six different sizes. The stretcher is available in a length of 1400mm, 1700mm or 1900mm, which enables it to fit both the size of the room and the height of the user.

KEY FEATURES

- No floor fixing required
- Ideal for a wet room environment
- Stainless steel frame with powder coated finish
- Permanently fixed at the desired height
- Available in 6 sizes
- Length of stretchers available; 1400mm - 1900mm in 100mm increments
- Weight capacity of 200kg
- Folds away to save on space
- Wipe clean surfaces
- Optional integral vinyl headrest on any sizes with paddle lift adjustment
- Optional 1400mm safety guard

Stainless Steel Powder Coated		Size	User Weight kg	Table Dimensions			Travel Range H mm	Wall Frame Width A mm	Wall Frame Depth B mm	Safety Guard Height Y mm	Stored Width S mm	Shipping Weight kg
Without Headrest	With Headrest			L mm	W mm	M mm						
3171	3271	1	200	1400	650	1000	Fixed	665	80	145*	240	75
3172	3272	2	200	1500	650	1000	Fixed	665	80	145*	240	76
3173	3273	3	200	1600	650	1000	Fixed	665	80	145*	240	77
3174	3274	4	200	1700	650	1000	Fixed	665	80	145*	240	78
3175	3275	5	200	1800	650	1000	Fixed	665	80	145*	240	79
3176	3276	6	200	1900	650	1000	Fixed	665	80	145*	240	80

*safety guard is optional accessory

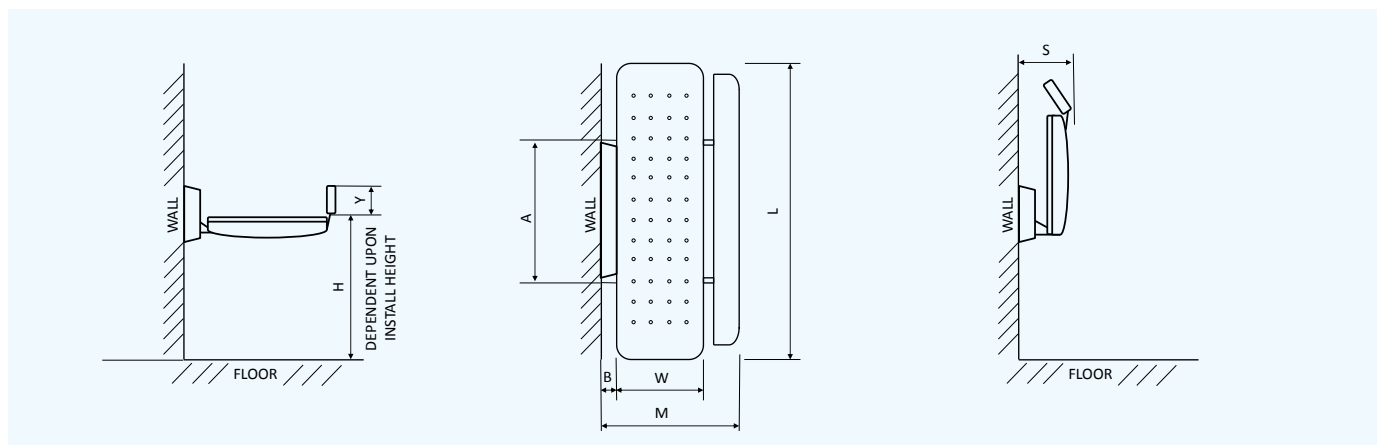

Colour range

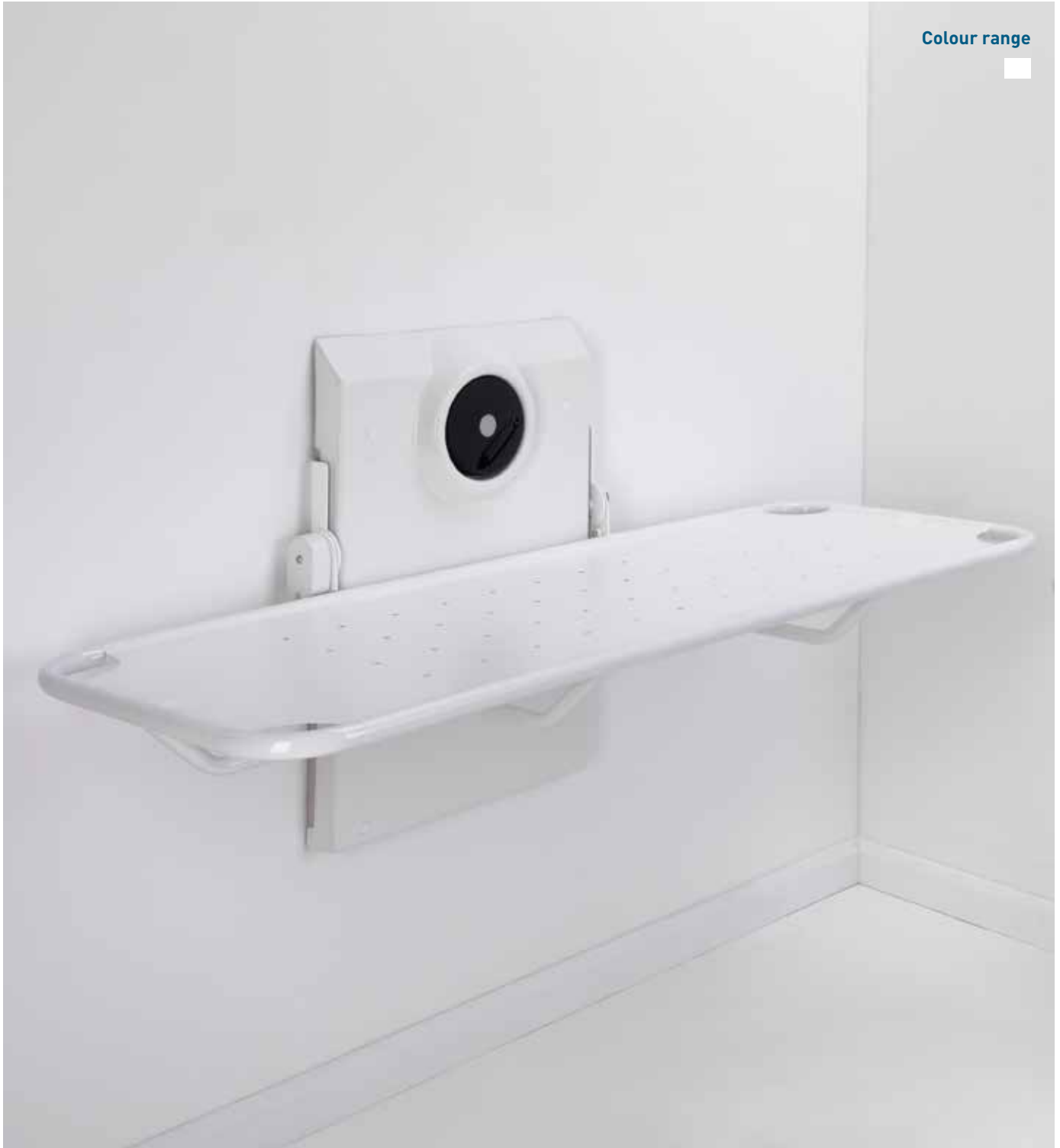

The Easi-shower range

Shower stretcher adjustable height

Wall mounted

The Shower stretcher adjustable height is wall mounted and does not require fixing to the floor. Its stainless steel frame and vinyl cover makes it perfect for any room environment.

Added safety

The safety guard is an optional accessory, available for all of our shower stretcher products, designed to give carers peace of mind whilst showering the user. The safety guard locks securely in to position and provides extra support whilst the user is on the stretcher. For more details please refer to page 21.

Space saver

The Shower stretcher adjustable height is ideal for rooms that have limited space. The fold-away functionality of the stretcher allows it to be stored away when it is not being used, allowing maximum use of room space.

Height adjustable

The Shower stretcher adjustable height allows you to manually set the height of the stretcher to the desired position, simply by turning the handle clockwise to lower and anti-clockwise to elevate.

KEY FEATURES

- Height range is manually operated
- No floor fixing required
- Ideal for a dry or wet room environment
- Stainless steel frame with powder coated finish
- Available in 6 sizes
- Length of stretchers available; 1400mm - 1900mm in 100mm increments
- Weight capacity of 200kg
- Travel range of 350mm
- Folds away to save on space
- Wipe clean surfaces
- Optional integral vinyl headrest on any sizes with paddle lift adjustment

Stainless Steel Powder Coated		Size	User Weight	Table Dimensions			Travel Range	Wall Frame Width	Wall Frame Depth	Safety Guard Height	Stored Width	Shipping Weight
Without Headrest	With Headrest		kg	L mm	W mm	M mm	H mm	A mm	B mm	Y mm	S mm	kg
3181	3281	1	200	1400	650	1000	450 - 800*	665	80	145**	240	80
3182	3282	2	200	1500	650	1000	450 - 800*	665	80	145**	240	81
3183	3283	3	200	1600	650	1000	450 - 800*	665	80	145**	240	82
3184	3284	4	200	1700	650	1000	450 - 800*	665	80	145**	240	83
3185	3285	5	200	1800	650	1000	450 - 800*	665	80	145**	240	84
3186	3286	6	200	1900	650	1000	450 - 800*	665	80	145**	240	85

*depending on installed height **safety guard is optional accessory

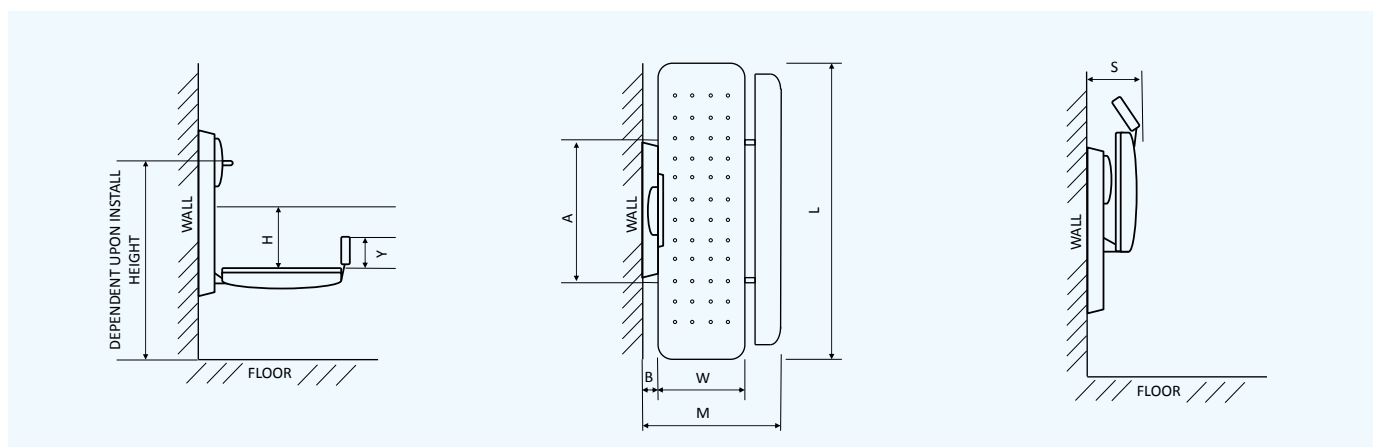

Easi-Change Accessories

Headrest

Products: Easi-lift shower stretcher, Shower stretcher fixed height & Shower stretcher adjustable height

Our 3 shower stretcher products can all be enhanced with the optional integral vinyl headrest. The headrest must be ordered at the same time the stretcher is ordered and cannot be fitted retrospectively. Our frames have been designed with the ability to have the headrest at each end of the stretcher (please specify which end, at point of order). The headrest features a paddle lift adjustment, which allows it to be locked securely in the desired position.

CODE: Please refer to product



Safety Guard

Products: Easi-lift shower stretcher, Shower stretcher fixed height & Shower stretcher adjustable height

Enhance the safety of any of the 3 shower stretcher products with the safety guard accessory. The safety guard must be ordered at the same time the stretcher is ordered and cannot be fitted retrospectively. The safety guard locks securely into position and provides extra support whilst the user is on the stretcher. Please note that the safety guard does not stow away (as per the Mobi changer). The safety guard is one size in length (1400mm).

CODE: ECSG01



Angled Back

Products: Mobi changer

The angled back is only available for the powder coated Mobi changer and must be requested when placing an order, as it cannot be fitted retrospectively.

The angled back support option enables a carer to find the ideal supportive angle for the user, making changing or showering more comfortable.

SIZE 1 CODE: BE002

SIZE 2 CODE: BE003

SIZE 3 CODE: BE004



Additional charging station & battery

CODE CB008 (charger & battery)

CODE BE005 (battery only)

Relevant products: Mobi Changer

Summary of product suitability depending on room environment

Environment	Suitable Products
Dry room environment	Powder coated benches (PC mobi, easi-lift & hi-riser)
Damp room environment i.e. bath/changing rooms (not for use with direct water)	Stainless steel benches (SS mobi & ss hi-riser)
Wet room environment i.e. walk in shower	Shower trollies, easi-lift shower stretcher & hi-riser shower stretcher

Easi-Change Colour range

Easi-Change solutions

Easi-Change is dedicated to finding solutions for children and adults that can not change or shower independently. Our dedicated design team collaborate with therapists to create and design products that provide effective solutions. Easi-Change products are available in varying sizes and colours, this is to ensure that our products meet the requirements of the environment, user and carer.

For peace of mind, all Easi-Change products come with a 2-year Manufacturer's warranty as standard.

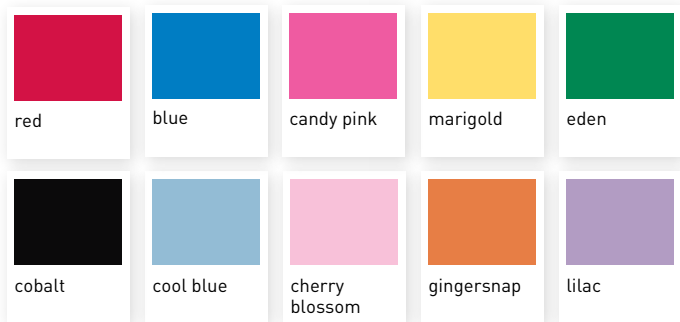
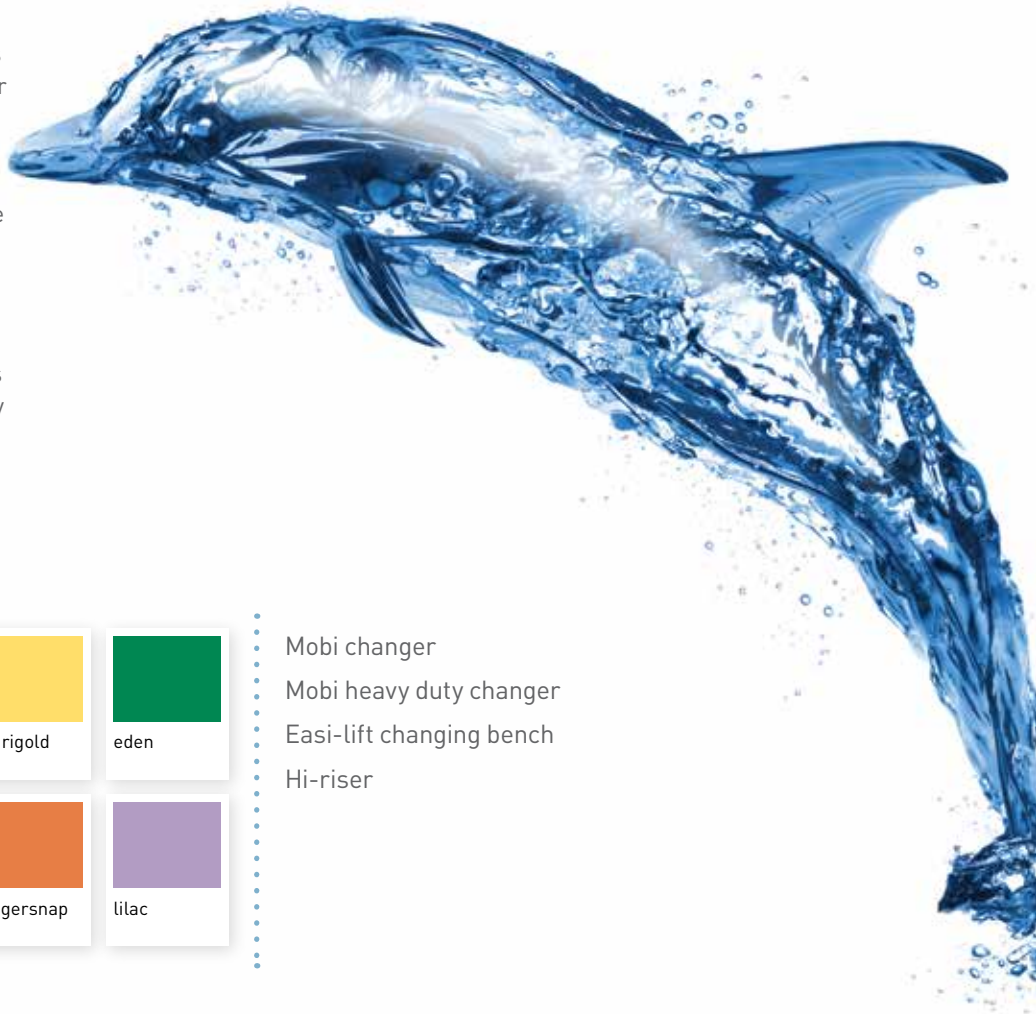

- Mobi changer
- Mobi heavy duty changer
- Easi-lift changing bench
- Hi-riser



- Shower stretcher fixed height
- Shower stretcher adjustable height
- Easi-lift shower stretcher



- Mobi shower trolley
- Hi-riser shower stretcher



DISTRIBUTOR CONTACT DETAILS

Easi-Change
17 Wentworth Road,
Heathfield, Newton Abbot
TQ12 6TL
T: +44 (0) 845 519 2121
F: +44 (0) 1626 835428
E: info@easi-change.co.uk
www.easi-change.co.uk

