

INDIGO HILO

INSTRUCTIONS FOR USE



CONTENTS

1.0	Introduction	1
2.0	Illustration of Your Indigo HiLo Seating System	2
2.1	Technical Data	2
3.0	For your Safety	3
4.0	Unpacking your Indigo HiLo Seating System	4
5.0	Setting up and Adjusting your Indigo HiLo Seating System	5
5.1	Seat Adjustments	5
5.2	Backrest Adjustments	7
5.3	Armrests	9
5.4	Braking System	10
5.5	Pelvic Lap Strap	12
6.0	Optional Accessories – Fitment and Adjustment	13
6.1	Headrests	14
6.2	Flip-up Footrest	16
6.3	Pommel	17
7.0	Care and Maintenance	18
7.1	Charging the battery	18
7.2	Daily Checks.....	19
7.3	Annual Service	19
7.4	Nominal Service Life	19
7.5	Extending Nominal Service Life	20
7.6	Documentation/Records	21
7.7	Product Configuration	21
8.0	Warranty & Service	22
9.0	Continuous Improvement	22
10.0	Warranty & Aftersale	23
10.1	Product Information.....	23
10.2	Service & Inspection Record Form	23

1.0 INTRODUCTION

Thank you for choosing the Indigo HiLo seating system from Smirthwaite.

The IndiGO seating system has been designed for use by teenagers who have mild to moderate postural management needs. It has been styled to enhance inclusivity into modern environments, and is particularly suitable for use by children who attend mainstream school on a periodic basis.

The IndiGO provides a range of features as standard including adjustable back height and recline angle as well as seat height, depth and tilt angle. The chair includes height adjustable armrests which can be quickly rotated rearwards to provide easy side transfer in and out of the chair.

Postural management can be specifically customized to suit a client's needs by adjusting the integrated lumbar prompt and thoracic supports.

When ordered, the product can be configured with a high back or low back option.

A range of accessories are available including a pommel, pelvic lap strap, 4-point harness, flat headrest (height, depth and angle adjustable), a 'Multi-grip' headrest (height, depth, angle and profile adjustable), and a height adjustable footrest with flip-up foot plates. Smirthwaite can also provide a range of sandals if required.

The IndiGO electric HiLo base includes a user operated brake mechanism and control pad to provide additional independence and positional security for clients.



IMPORTANT!

These instructions should be read by all therapists and carers using the equipment and should be retained for future reference. The product should always be used under adult supervision.

A clinical assessment of the child's needs should be undertaken to ensure the Samba chair is correctly adjusted. Adjustments should only be made by a therapist, Smirthwaite Technical Product Advisor or suitably trained personnel.

Any incorrect use of the product and failure to follow the instructions may put the user at risk or impede the function. If you have any queries using this product or wish for further copies, please do not hesitate to contact our Customer Service Team on T: +44 (0)1626 835552.

This product has been designed and manufactured specifically and solely for use by clients with special needs.

2.0 ILLUSTRATION OF YOUR INDIGO HILO SEATING SYSTEM

1. Electric HiLo Chassis
2. Seat Capsule
3. Backrest
4. Armrests
5. Footrest
6. Battery Pack
7. Pommel
8. Lap Strap
9. User operated brakes

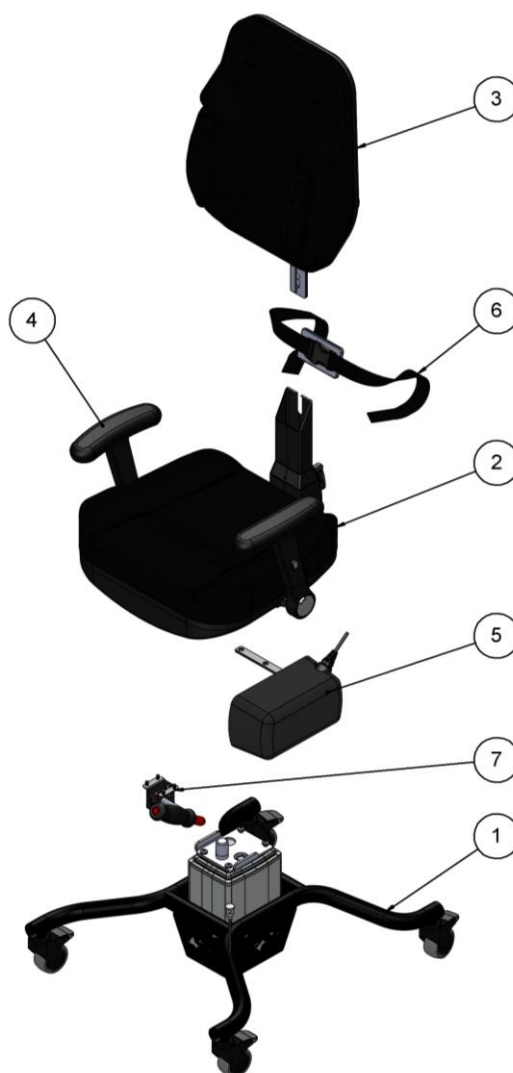

2.1 TECHNICAL DATA

Measurement	Size 3	Size 4	Size 5
Seat Height – Floor to seat top (mm)	510 - 760	510 - 760	510 – 760
Seat Depth (mm)	290 - 370	340 - 420	390 – 470
Seat Width (mm)	390	440	490
Seat Angle – Prone to supine (°)	3 – 10	3 – 10	3 – 10
Back Angle – Prone to supine (°)	0 - 15	0 - 15	0 – 15
Low back height (mm)	370 - 450	420 - 500	420 – 500
Low back height (mm)	490 - 550	560 - 640	560 – 640
Headrest height from top of backrest (mm)	100 - 200	100 - 200	100 – 200
Armrest height (mm)	190 - 250	190 - 250	190 - 250
Seat to footrest (mm)	260 - 340	340 - 490	340 - 490
Footprint width x length (mm)	615 x 700	615 x 700	615 x 700
Max user weight (kg)	100	125	150
Product weight (kg)	42	43	44

3.0 FOR YOUR SAFETY



STOP!

Please read these instructions **CAREFULLY** and **THOROUGHLY**.

Always lock the castors when attaching items, or making adjustments.

There are two methods to lock the brakes on the Indigo HiLo chair:

- 1) Push the brake lever downwards to simultaneously apply the brake to all four castors, or
- 2) Apply foot to point (A); to unlock, apply foot to point (B) on each individual castor

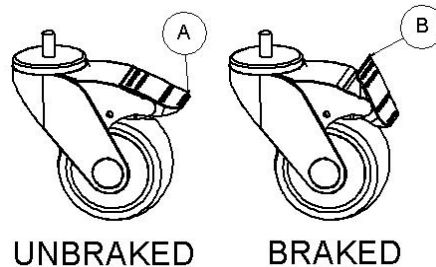

- The user should **NOT** be left unattended whilst in the product. Always ensure a responsible therapist or carer is in attendance
- The carer should be familiar with the methods of adjustment and have completed all adjustments appropriately to meet the needs of the child before transferring the child into the product
- Regular maintenance checks and cleaning are essential for the safe use of this equipment (see care and maintenance section)
- Ensure that all nuts, bolts and hand wheels are securely tightened and that none are missing
- The chassis is **ONLY** to be used indoors on a flat level surface
- Always keep this product away from naked flames, cigarettes and sources of heat including open fireplaces, radiators and heaters.
- Always keep this product away from naked flames, cigarettes and sources of heat including open fireplaces, radiators and heaters
- **DO NOT** fit parts or accessories of other manufacturers to this product unless authorized to do so in writing by Smirthwaite Ltd. Failure to follow these instructions will not only invalidate the guarantee but could make the product dangerous to use. Smirthwaite Ltd will not accept liability for any injury or damage incurred through such malpractices
- Any repairs required must be carried out by Smirthwaite Ltd authorized personnel
- If you believe the product or any fitted accessory to be faulty at any time, **DO NOT USE** – contact Smirthwaite Ltd by telephone on +44 (0)1626 835552



STOP!

LAP STRAPS & HARNESSSES SAFETY NOTICE

Lap straps and harnesses must be appropriate and safe for the user and the users clothing.

Lap straps and harnesses must be checked every time the chair is used to ensure they are fitted as prescribed by the clinician, take account of the users clothing and are tightened so that the user cannot sustain injury. Checking the fit of lap straps and harnesses must be done with the user in the chair and should be undertaken as soon as the users sits in the chair.

4.0 UNPACKING YOUR INDIGO HILO SEATING SYSTEM



STOP!

If in any doubt, **ALWAYS** seek **ADVICE**.

Always turn hand wheels, levers and screws clockwise to tighten or anti-clockwise to loosen.

- When delivered the product will be supplied with the back rest (A) removed.
- Unwind lever (C) and insert back rest (A) into the back mechanism (B) – ensure it is inserted fully.
- Tighten lever (C) to secure the back rest (A) into place.
- If you have specified accessories at the time of order, your IndiGO HiLo may be supplied with these factory fitted.
- Alternatively, please refer to Section 6.0 for details of how to fit and adjust your accessories prior to use

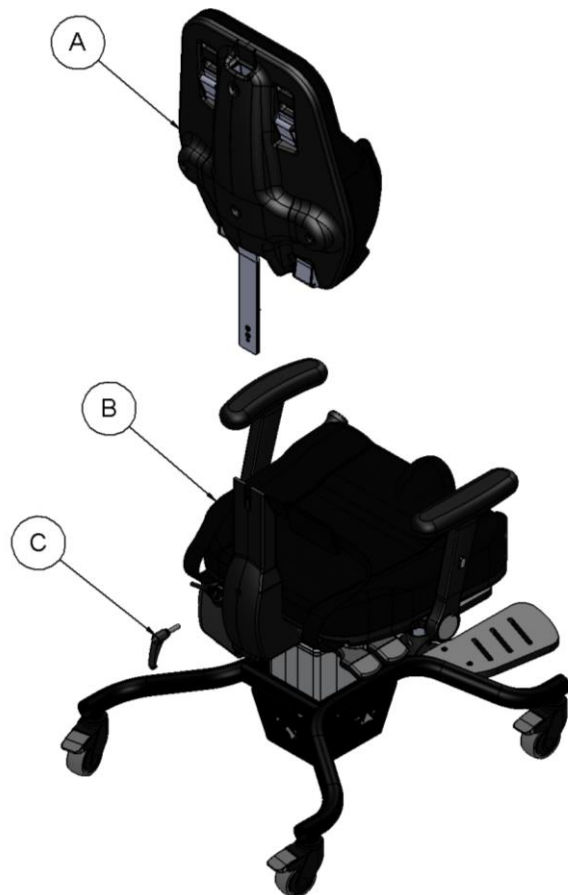



STOP!

If you believe this product to be faulty – DO NOT USE

Contact: Smirthwaite Ltd

T: +44 (0)1626 835552

F: +44 (0)1626 835428

E: enquiries@smirthwaite.co.uk

5.0 SETTING UP AND ADJUSTING YOUR INDIGO HILO SEATING SYSTEM



STOP!

If in any doubt, ALWAYS seek ADVICE.

Always turn hand wheels, levers and screws clockwise to tighten or anti-clockwise to loosen.

5.1 SEAT ADJUSTMENTS

3 adjustments can be made to the seat; **depth, height and tilt.**

5.1.1 DEPTH

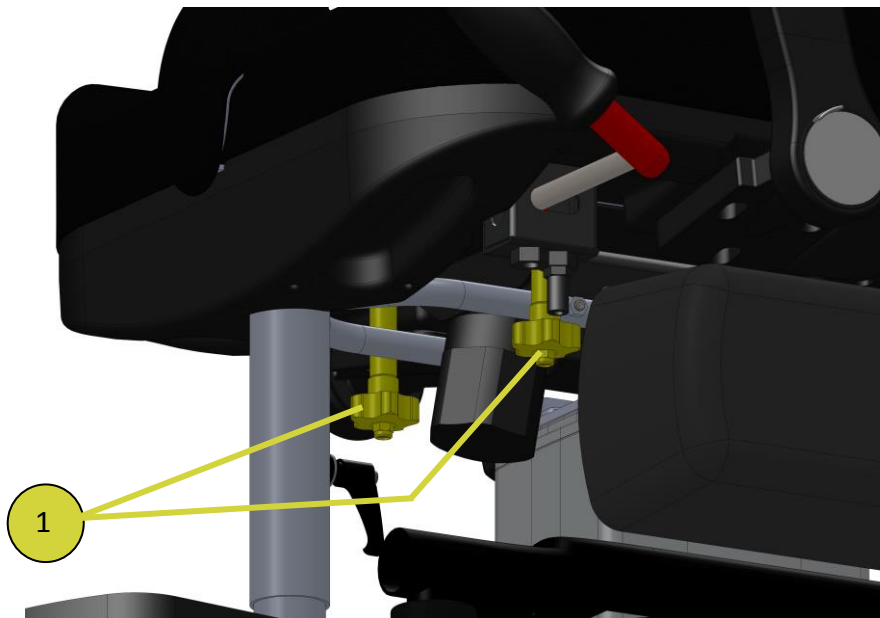

To move the seat base backwards or forwards:

- Locate the 2 hand wheels (1) underneath the seat base and loosen them.
- Slide seat to the desired position.
- Ideally allow 25mm gap between the back of knee and the edge of the seat.
- Tighten the 2 hand wheels to secure in position.

5.1.2 HEIGHT



- The height of the chair can be altered by using the 'Actuator Control Pad' (2) which is hooked onto the push handle of the chair. This pad can be unhooked and can be moved to a more suitable position if required.
- Push either the 'Up' arrow or the 'Down' arrow to move the chair to the required height. Only press one arrow button at a time.

5.1.3 TILT IN SPACE

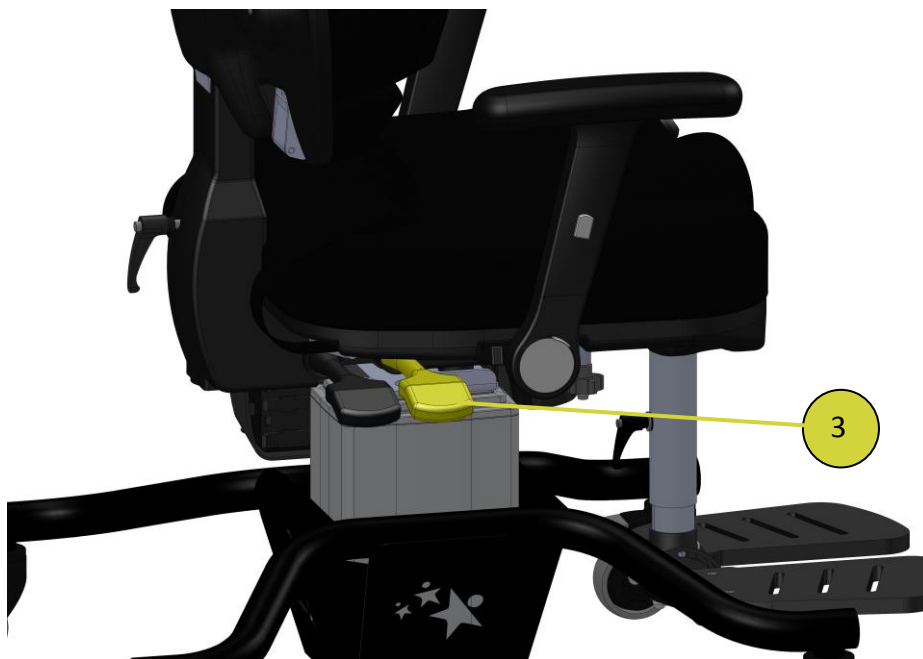

To adjust the tile angle of the seat:

- Lift the front lever (3) on the side of the chair to unlock the tilt mechanism.
- Adjust the seat tilt to the desired position.
- Push the lever back down to lock the seat in the desired position.

5.2 BACKREST ADJUSTMENTS

5.2.1 BACK RECLINE (ANGLE)



To adjust the angle of the backrest:

- Lift the back lever (4) on the side of the chair to unlock the backrest tilt mechanism.
- Adjust the back rest to the desired angle.
- Push the lever back down to lock the back rest in position.

5.2.2 BACK REST HEIGHT

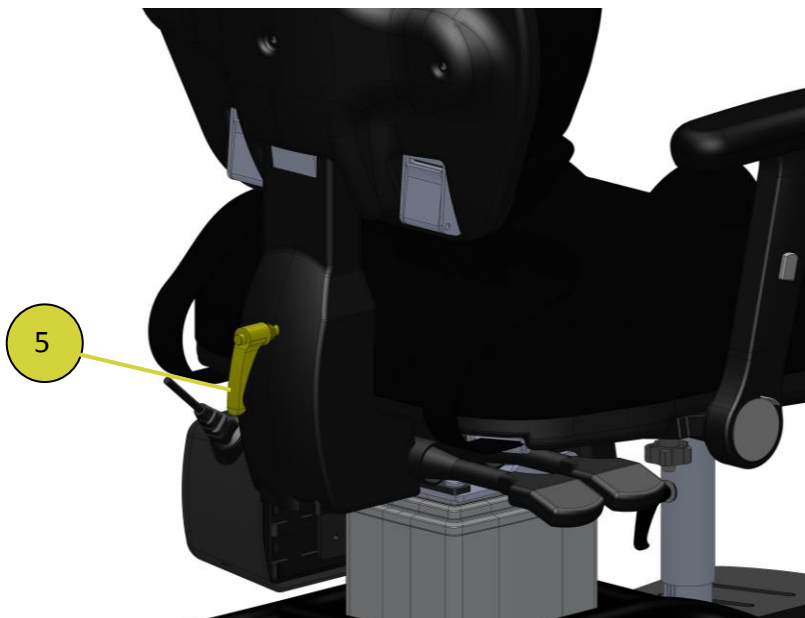

To adjust the height of the backrest:

- Locate the lever lock on the back of the chair (5) and loosen it.
- Slide the backrest up or down to the desired position.
- Tighten the lever lock to secure the backrest in position.

5.2.3 BACK LUMBAR PROMPT

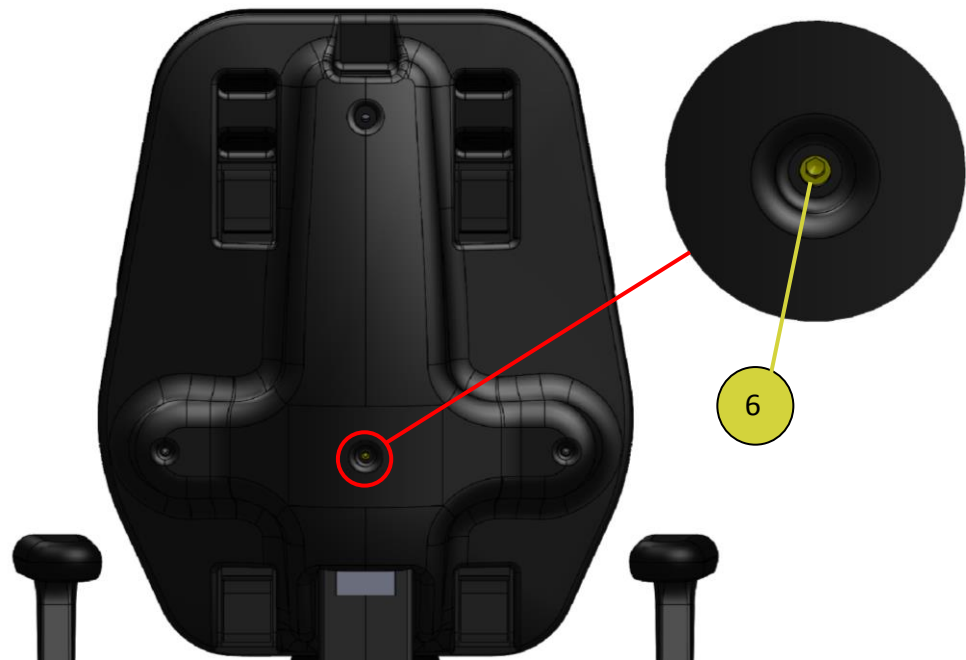

To set the lumbar support, insert the supplied 4mm hex key into the central socket on the back of the chair (6). Turn clockwise or anti-clockwise to set the lumbar support to the required depth for the user.

5.2.4 THORACIC SUPPORT



Each thoracic support can be set independently by inserting the provided 4mm hex key into either of the outer sockets on the back of the chair (7). Turn clockwise or anti-clockwise to set each thoracic to the required angle for the user.

5.3 ARMRESTS

The armrests can be rotated out of the way to aid in the transfer of the user. Also the height of the armrests can be adjusted.

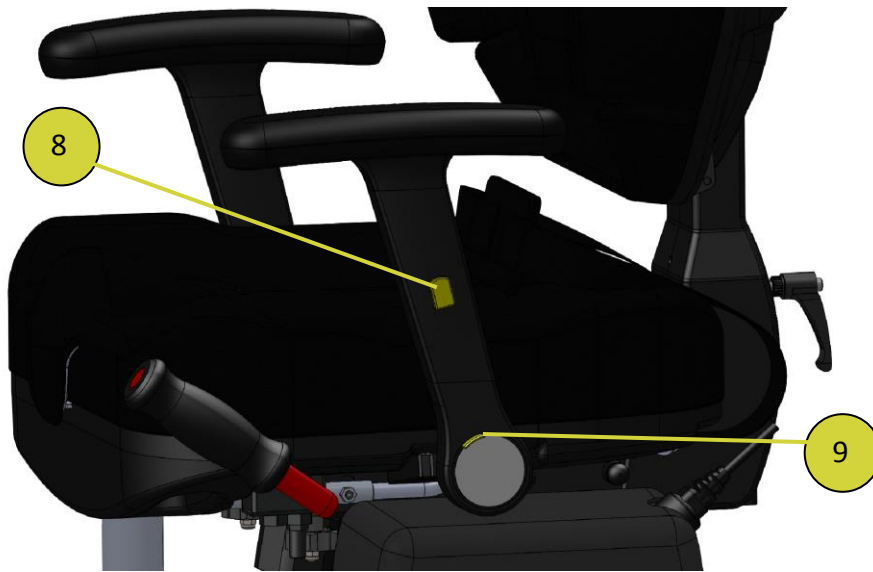

ARMREST UP

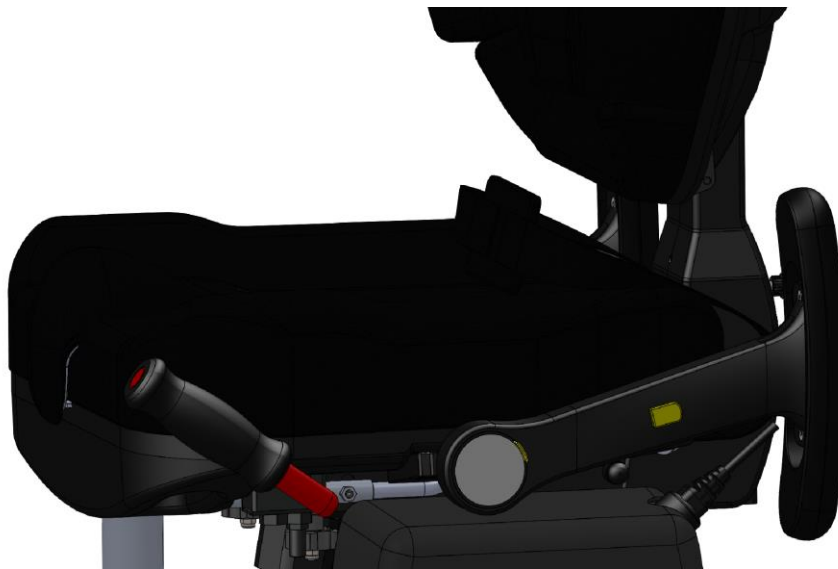

ARMREST DOWN

5.3.1 HEIGHT

To **raise or lower** the armrests:

- Press and hold the button midway up the outside face of the armrest (8).
- Slide the armrest up or down slightly and release the button.
- Continue to move the armrest up or down until the button 'clicks' out.
- Repeat this step until the armrest is at the desired height.
- Repeat for the other armrest.

5.3.2 ROTATION

To rotate the armrests out of the way:

- Press and hold the button towards the base of the armrest (9).
- Push the armrest backwards slightly and then release the button.
- Continue to push the armrest backwards until the button 'clicks' out and the armrest is in its lowered position.
- To raise the armrests, push the button back in and rotate the armrest upwards.
- Release the button and continue to rotate the armrest upwards until the button 'clicks' out and the armrest is in its up position.

5.4 BRAKING SYSTEM

5.4.1 USER OPERATED BRAKES

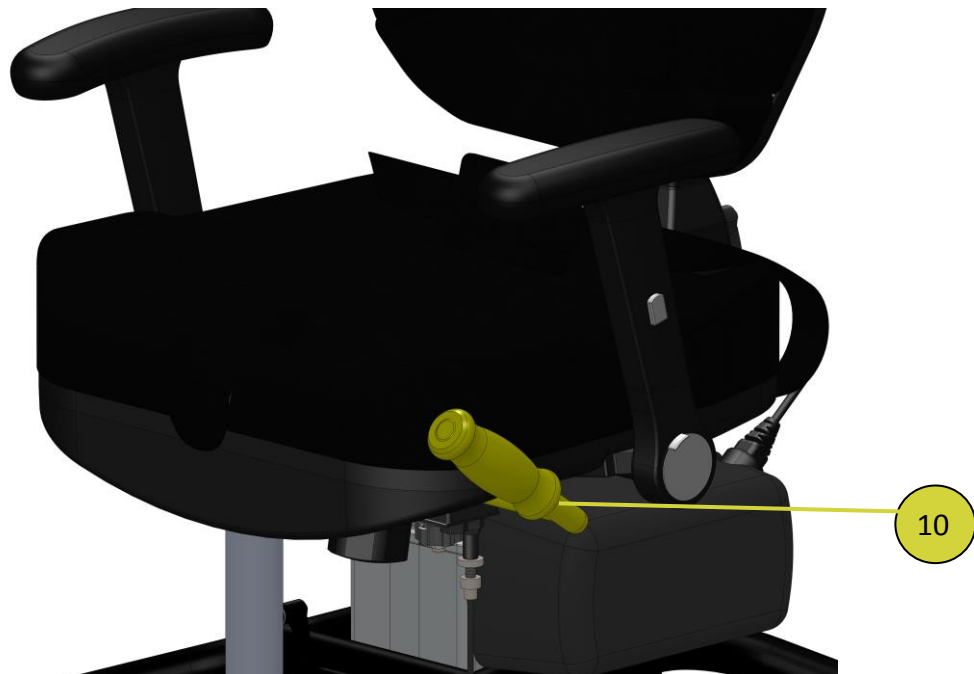

- To apply the brakes, simply push the lever (10) downwards.
- The brakes can then be locked in the 'on' position by parking the lever – simply push the lever away from the seat cushion when it has reached its fully downward position.
- To release the brakes, pull the lever toward the seat to release from its park position.
- The lever is sprung-loaded; once it is released it will automatically return to its top position.
- **Note:** The brake lever can be on either side of the chair depending on the order.

5.4.2 CARER OPERATION

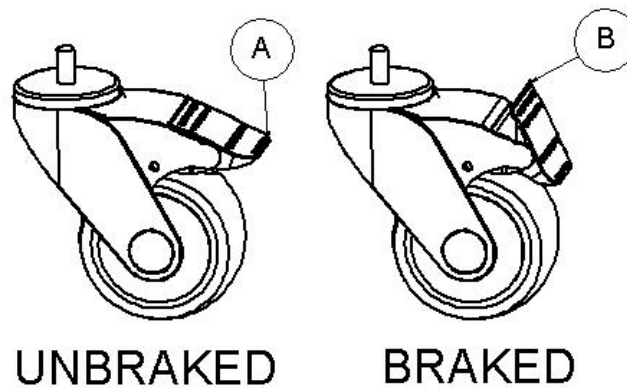

The IndiGO has been designed to permit any of the castors to be independently applied or released by a carer, using each individual castor foot pedal. For instructions on how to use the castor brakes see section '3.0 For your Safety'.



IMPORTANT!

If the user is having difficulty operating the brake system, check that the brake pedal on each castor is in the 'unbraked' position.

5.4.3 BRAKE SYSTEM ADJUSTMENT

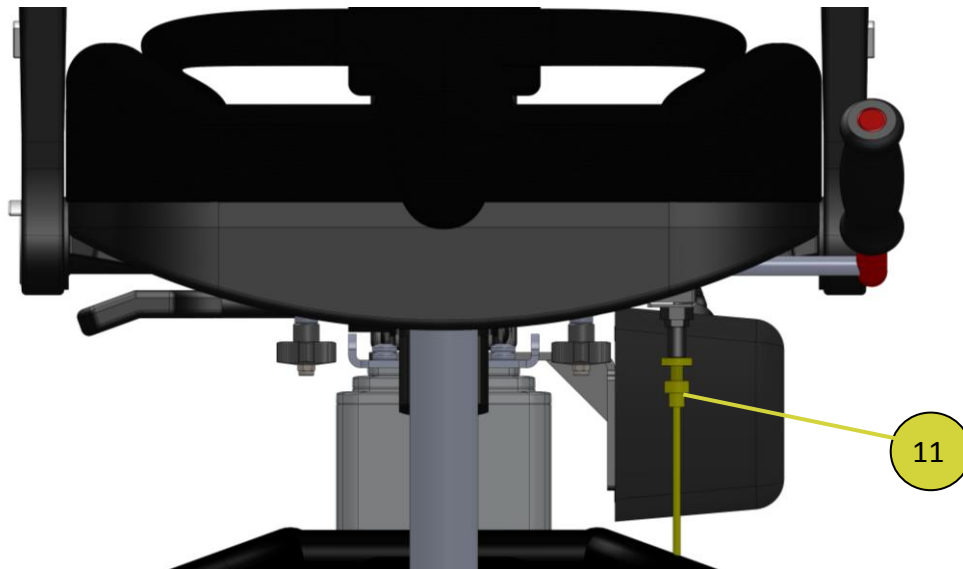

- Adjustment of the brake mechanism is possible by rotating the adjustment knob (11) that can be found underneath the seat base.
- The IndiGO will be supplied pre-adjusted for optimum use; adjustment is only needed if the mechanism performance degrades over long term use.

5.5 PELVIC LAP STRAP

5.5.1 BUCKLE

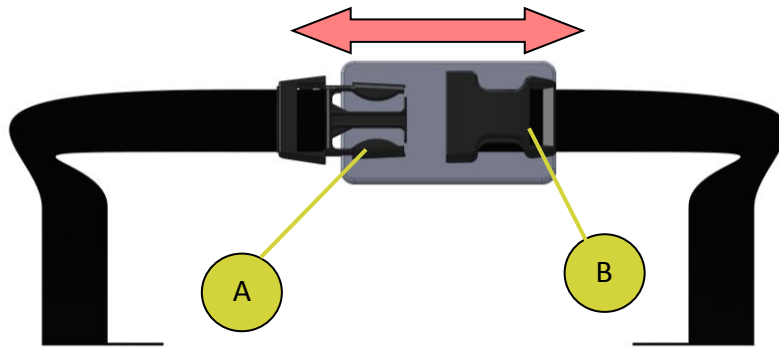

- The IndiGO HiLo is supplied with a 2-point pelvic padded lap strap as standard.
- The buckle is secured by pushing the male plug (A) into the female receiver (B).
- To release the buckle, press both sides of the male plug and pull apart.

5.5.2 LENGTH ADJUSTMENT

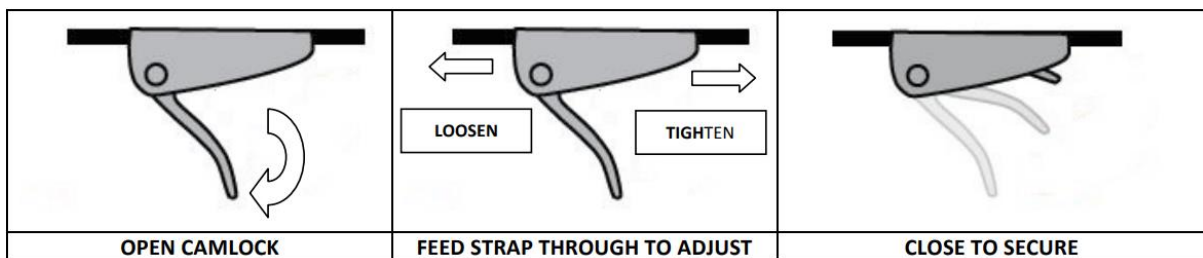
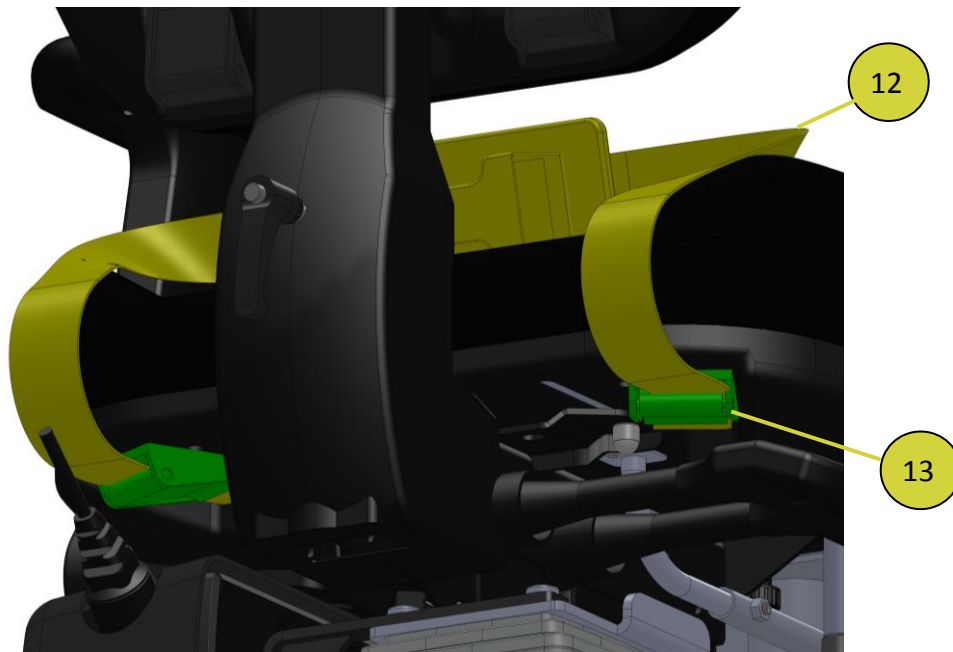

- To alter the length of the pelvic strap (12), simply adjust the amount of strap that is fed through the cam-lock fasteners (13), which are located under the seat base at the rear.
- The steps to operate the cam lock can be seen in the above diagram.

6.0 OPTIONAL ACCESSORIES – FITMENT AND ADJUSTMENT

1. Multi-grip head rest
2. Flat head rest
3. Pommel
4. Flip-up footrest



6.1 HEADRESTS

6.1.1 FITMENT

- Insert the stem of the headrest (14) into the socket on the rear of the seat back (15).
- Take the supplied M6 x 20mm screw (16) and washer (17) and insert the screw through the aperture (18) and into the insert located in the head rest stem.
- Tighten the screw with the supplied 4mm hex key.

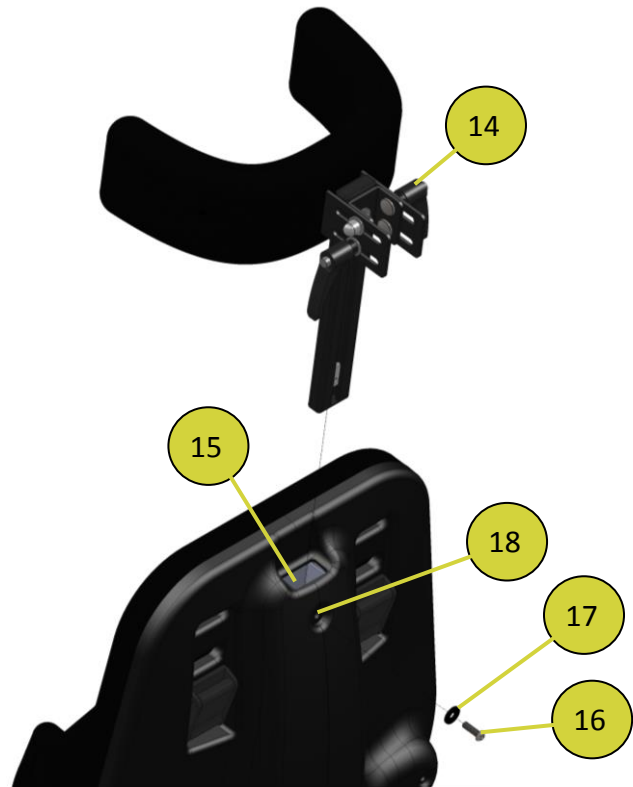

6.1.2 HEADREST HEIGHT

The height of the headrest can be altered in 2 stages.

- Using the supplied hex key, loosen the bolt on the back of the padded headrest assembly (19).
- Slide the headrest to the desired position and tighten the bolt to secure in place.
- Using the supplied hex key, loosen the M6 x 20 screw used for the fitment of the headrest assembly (16)
- Slide the whole headrest assembly to the desired position and tighten the screw to secure in place.

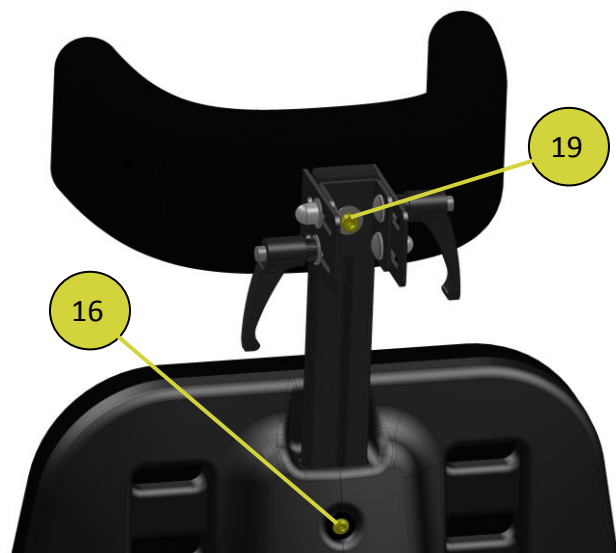

6.1.3 DEPTH AND ANGLE

To change the depth and/or angle of the headrest:

- Loosen the two lever locks (20).
- Slide/angle the headrest to desired position.
- Tighten the two lever locks (20) to lock.



6.1.4 HEADREST PROFILE/SHAPE – (MULTI GRIP HEAD REST ONLY)

To alter the profile (shape) of the headrest:

- Locate and unzip the cover of the headrest.
- Using the hex key, loosen the bolts that secure the individual headrest elements (21).
- Position/shape the headrest elements to suit your client's needs.
- Tighten the headrest elements (21) to lock into the desired profile (shape).
- Zip the cover shut on the headrest to complete.

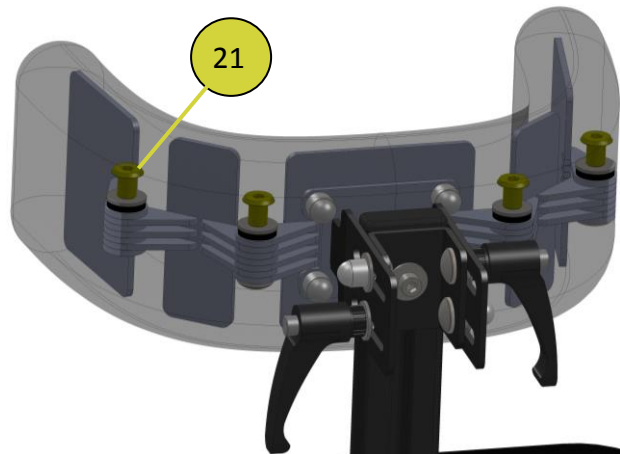

6.2 FLIP-UP FOOTREST

6.2.1 FITMENT

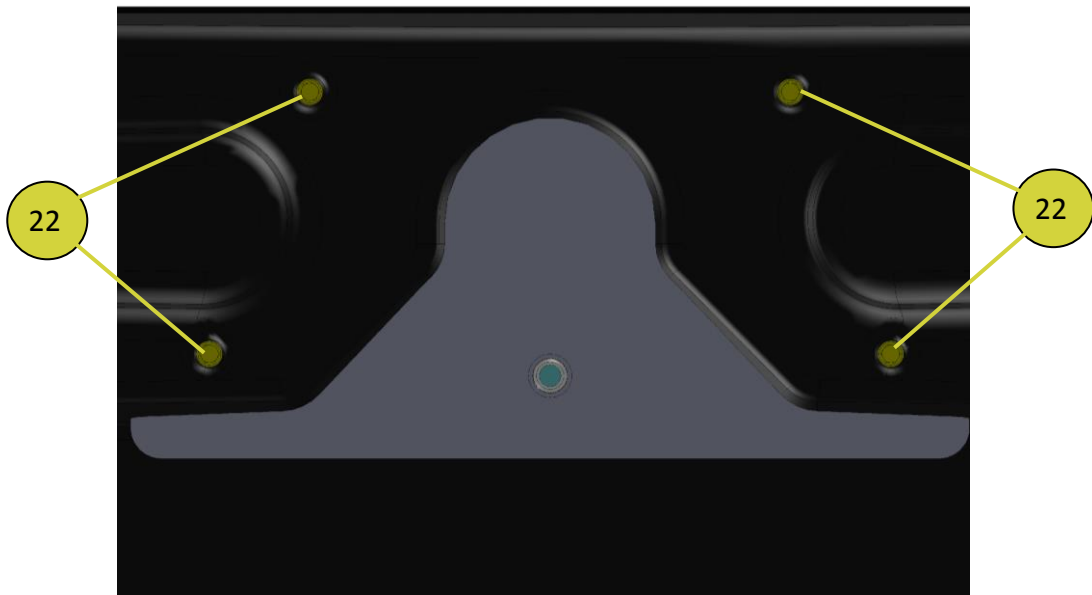

The foot rest assembly is attached to the underside of the seat base by 6 screws (M6 x 16mm). Four of these will already be fitted to the underside of the seat by the factory located toward the front of the chair (22).

- Using the hex key provided, ensure the four screws fitted to the underside of the seat are loose.

- Offer up the footrest (23) to the underside of the seat and slide forward. The slots in the front of the footrest are to engage with the screws mentioned in the previous step.
- Insert 2 further screws (24) at the rear and tighten using the supplied hex key.
- Tighten the 4 screws at the front of the footrest using the supplied hex key.

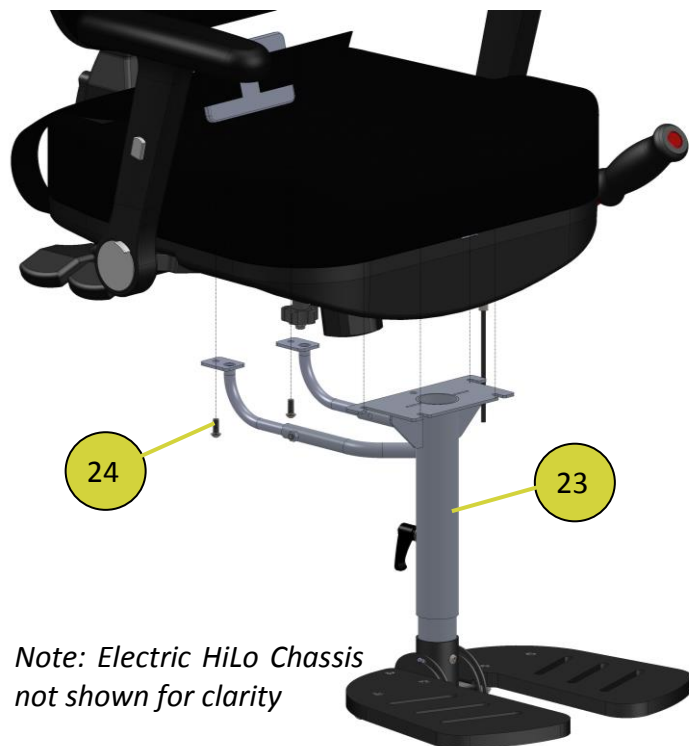

Note: Electric HiLo Chassis not shown for clarity

6.2.2 HEIGHT

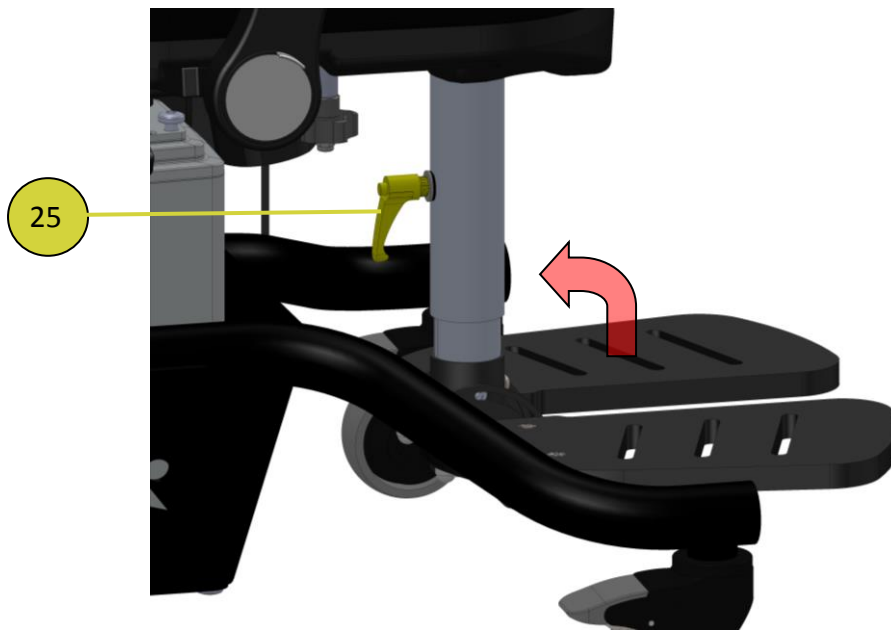

To adjust the height of the footrest:

- Locate the lever lock on the back side of the footrest assembly (25) and loosen it.
- Slide the footrest assembly up or down to the desired position.
- Tighten the lever lock to secure the footrest in position.
- Each footrest board can be flipped up and stored vertically to aid transfer in and out of the chair.

6.3 POMMEL

- Insert the Pommel (26) through the slot at the front of the seat base.
- Insert the grip knob (27) through the base of the chair and into the pommel.
- Tighten the grip knob to secure.

Note: If the footrest is attached, the grip knob will have to go through the footrest, then the base and then into the pommel.



7.0 CARE AND MAINTENANCE



IMPORTANT!

CLEANING IS RECOMMENDED ON A REGULAR BASIS

- Clean wooden parts and upholstery with a damp cloth and mild detergent.
- Clean metalwork with a damp cloth.
- Stubborn marks on the woodwork or cushions should be cleaned using a soft brush
- Do not soak or immerse the product in water
- Store the product in a cool dry place and out of direct sunlight
- DO NOT use bleach, solvents, abrasives, synthetic detergents, wax polishes, antibacterial sprays or wipes
- Operating temperature for the actuator is +5°C - +40°C
- The actuator should be used for no more than 2 minutes at a time followed by a downtime of at least 18 minutes.
- For further information, please refer to your regional healthcare cleaning guidelines

7.1 CHARGING THE BATTERY

- Apply the brakes to the castors before charging. Also do not use the chair whilst charging.
- When the battery is low a buzzer will sound. When this happens plug the charging cable into the socket on the battery pack assembly.
- Plug the other end of the cable into a mains socket and turn on to begin charging the battery.
- The battery will become fully charged in approximately 6 hours.

7.2 DAILY CHECKS

- Check for signs of wear, tear or damage
- Check for missing parts
- Check that all screws are present and tighten correctly, and are not cross-threaded or damaged
- Check all straps for fraying, and that buckles are not missing/damaged
- Check that the castors run freely and the brakes on each castor function correctly
- Check that the high-low feature operates correctly
- Check that the tilt-in-space feature operates correctly
- Check that the battery is adequately charged.
- Check that the footplate is set to the correct height for the client, and that it is securely in place. (if footrest attachment used)

7.3 ANNUAL SERVICE

The IndiGO HiLo Seating System should be serviced annually. Servicing must only be undertaken by a Smirthwaite Ltd service engineer, or by a Smirthwaite Ltd trained representative.

7.4 NOMINAL SERVICE LIFE

Your product has a nominal service life of 7 years, during which full post-sales support will be available with regard to spares and servicing.

Product service life has been determined based upon the design complexity of product, and the anticipated exposure to normal use.

Good practice dictates all Smirthwaite Ltd products have been designed and manufactured to high levels of safety and quality, and will meet requirements of normal use when maintained in line with our servicing recommendations.



STOP!

If the product has been out of use for an extended period of time (6 months or more) it should always be serviced prior to being re-issued.

If the product has been subjected to 'heavy' or 'constant' use, the service should be reduced to half the recommended period.

Constant and/or heavy use is considered to be:

- Daily use above 7 hours duration
- Weekly use above 5 days duration
- Monthly use above 10 months per year
- Use by a client who is at 90% to 100% of the maximum weight limit of the product. The maximum weight limit must **NEVER** be exceeded
- Use by a client who is extremely active, either voluntarily or involuntarily

7.5 EXTENDING NOMINAL SERVICE LIFE

At Smirthwaite Ltd we are proud to produce products that have a reputation for quality and durability.

We believe our products have the potential to provide benefits to our clients beyond the nominal service life documented above.

We will continue to provide full support beyond the nominal service life provided the following conditions are met:

1. A full service schedule has been maintained.
2. A full service and inspection is undertaken at the end of the nominal service life period.
3. The product is subsequently serviced annually (or biannually if under 'heavy/constant' use conditions).
4. Smirthwaite Ltd reserves the right to limit support where parts/components are no longer available.

7.6 DOCUMENTATION/RECORDS

- It is the responsibility of the current equipment owner to ensure the 'Instructions for Use' manual and any further manuals for accessories fitted to the equipment are handed over to the new owner at the time of exchange/sale.
- It is the responsibility of the current equipment owner to ensure the service and inspection record form is kept up to date.

7.7 PRODUCT CONFIGURATION

- Smirthwaite Ltd will document and maintain a record of the original product configuration at the time of first sale.
- Smirthwaite Ltd will not be held responsible for any subsequent changes to this configuration unless authorized to do so in writing by Smirthwaite Ltd.
- It is the equipment owner's responsibility to maintain their own records of changes to the equipment configuration and to be able to provide such records to subsequent owners to maintain traceability. We recommend an inspection/service by a Smirthwaite Ltd service engineer (or Smirthwaite Ltd trained engineer) whenever a significant change is made to product configuration to ensure the product is safe to use. **If in any doubt, ALWAYS seek ADVICE.**



IMPORTANT REMINDER!

DO NOT fit parts or accessories of other manufacturers to this product unless authorized to do so in writing by Smirthwaite Ltd.

Any servicing or repairs required must be carried out by Smirthwaite Ltd (or a Smirthwaite Ltd trained engineer).

If you believe this product to be faulty – DO NOT USE

Contact: Smirthwaite Ltd

T: +44 (0)1626 835552

F: +44 (0)1626 835428

E: enquiries@smirthwaite.co.uk

If in any doubt, ALWAYS seek ADVICE.

8.0 WARRANTY & SERVICE

Smirthwaite Ltd warrants the products detailed on your order to be free from defects in materials and workmanship for a period of 2 years from date of delivery. If a fault develops during the period, please call Customer Services by email or telephone 01626 835552 who will advise you on the best course of action. Possible action may be for us to arrange to send out one of our Service Engineers, or have the goods returned to us. Should a repair not be possible within the guarantee period we will replace the product for new or nearest equivalent product. In the unlikely event that we cannot repair or exchange we will refund in full.

This warranty is for the UK only. The warranty excludes faults due to accident, neglect, misuse, not following the Instructions and normal wear and tear. This warranty is in addition to your legal rights. Goods will only be collected from the original delivery address.

A charge may be made where the goods cannot be repaired under the terms of the warranty. You will be advised before this is made.

T: +44 (0)1626 835552 E: info@smirthwaite.co.uk

9.0 CONTINUOUS IMPROVEMENT

Smirthwaite Ltd are committed to continuous improvement to their product range. Should you have any suggestions or comments please contact our product design department, using enquiries@smirthwaite.co.uk

Smirthwaite Ltd reserves the right to change the specification or material without prior notice.

For catalogues, help and further information on our products please contact us at:

Smirthwaite Ltd

16 Wentworth Road

Newton Abbot

Devon, TQ12 6TL

T: +44 (0)1626 835552

F: +44 (0)1626 835428

E: enquiries@smirthwaite.co.uk

10.0 WARRANTY & AFTERSALE

10.1 PRODUCT INFORMATION

Model:	
Size:	
Date of Manufacture:	
Serial Number:	
Final Inspection:	

10.2 SERVICE & INSPECTION RECORD FORM

Date	Procedure	Service Personnel

CE



Smirthwaite Ltd, 16 Wentworth Road, Newton Abbot, Devon, TQ12 6TL

T: +44 (0)1626 835552 F: +44 (0)1626 835428 E: enquiries@smirthwaite.co.uk