

05/21



MOBI CHANGER

INSTRUCTIONS FOR USE

Codes 3121-3123 & 3141-3143



CONTENTS	PAGE
1.0 INTRODUCTION	1
2.0 ILLUSTRATION OF YOUR MOBI CHANGER	2
3.0 TECHICAL DATA	3
4.0 FOR YOUR SAFETY	4
5.0 UNPACKING YOUR MOBI CHANGER	5
6.0 SETTING UP AND ADJUSTING YOUR MOBI CHANGER	6
7.0 HOW TO USE YOUR MOBI CHANGER	8
8.0 CARE & MAINTENANCE	9
9.0 WARRANTY & SERVICE	13
10.0 CONTINUOUS IMPROVEMENT	13
11.0 SERVICE INSPECTION	14

1.0 INTRODUCTION

Thank you for choosing the Smirthwaite Mobi Changer.

The Mobi Changer is a fully mobile changing bench that requires no installation or fixing. Its compact design means that it can be easily manoeuvred from room to room making it an extremely cost effective option for a multi-use environment.



IMPORTANT!

These instructions should be read by all therapists and carers using the equipment and should be retained for future reference. The product should always be used under adult supervision.

Any incorrect use of the product and failure to follow the instructions may put the user at risk or impede the function. If you have any queries using this product or wish for further copies, please do not hesitate to contact Customer Service department on T: +44 (0)1626 835552



2.0 ILLUSTRATION* OF YOUR MOBI CHANGER

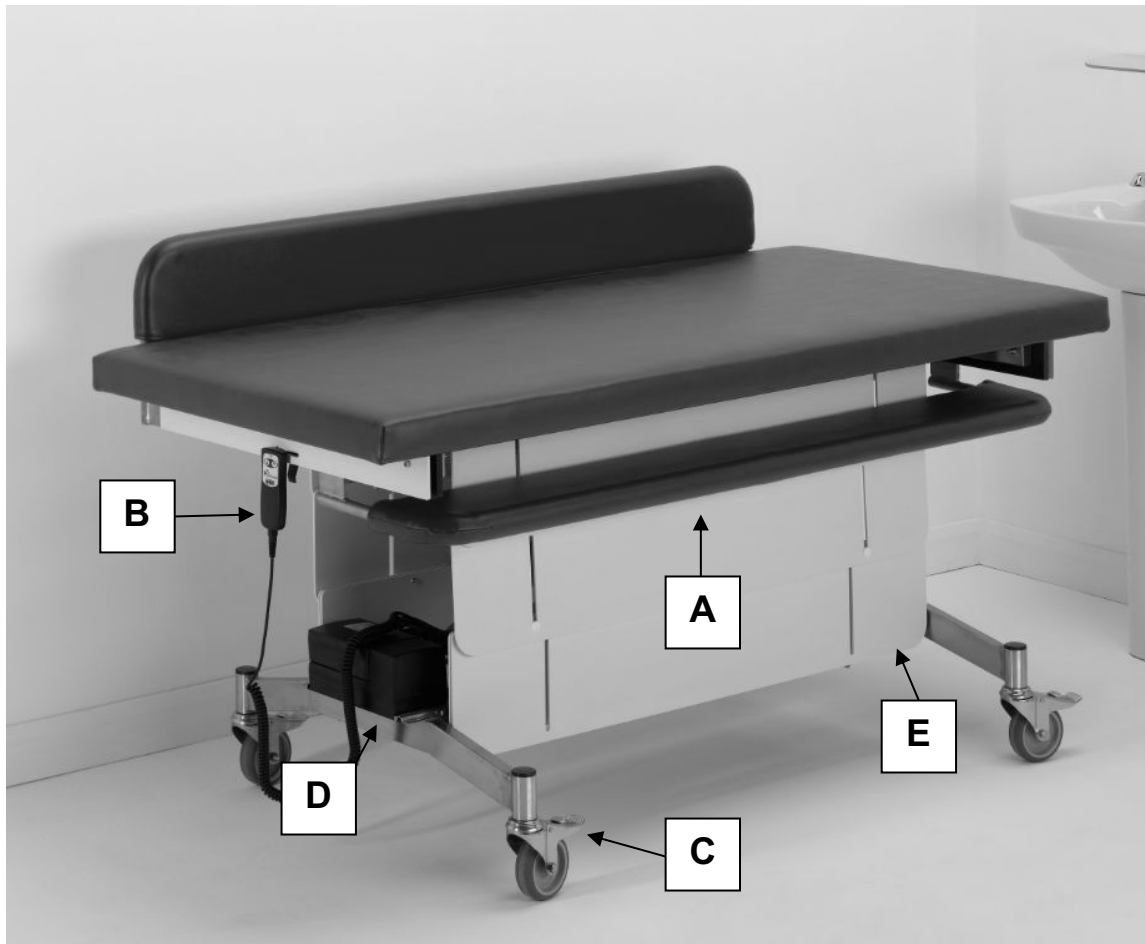

- A. Safety side
- B. Handset
- C. Castor
- D. Battery
- E. Safety skirt

* Illustrative only; some components may vary



3.0 TECHNICAL DATA

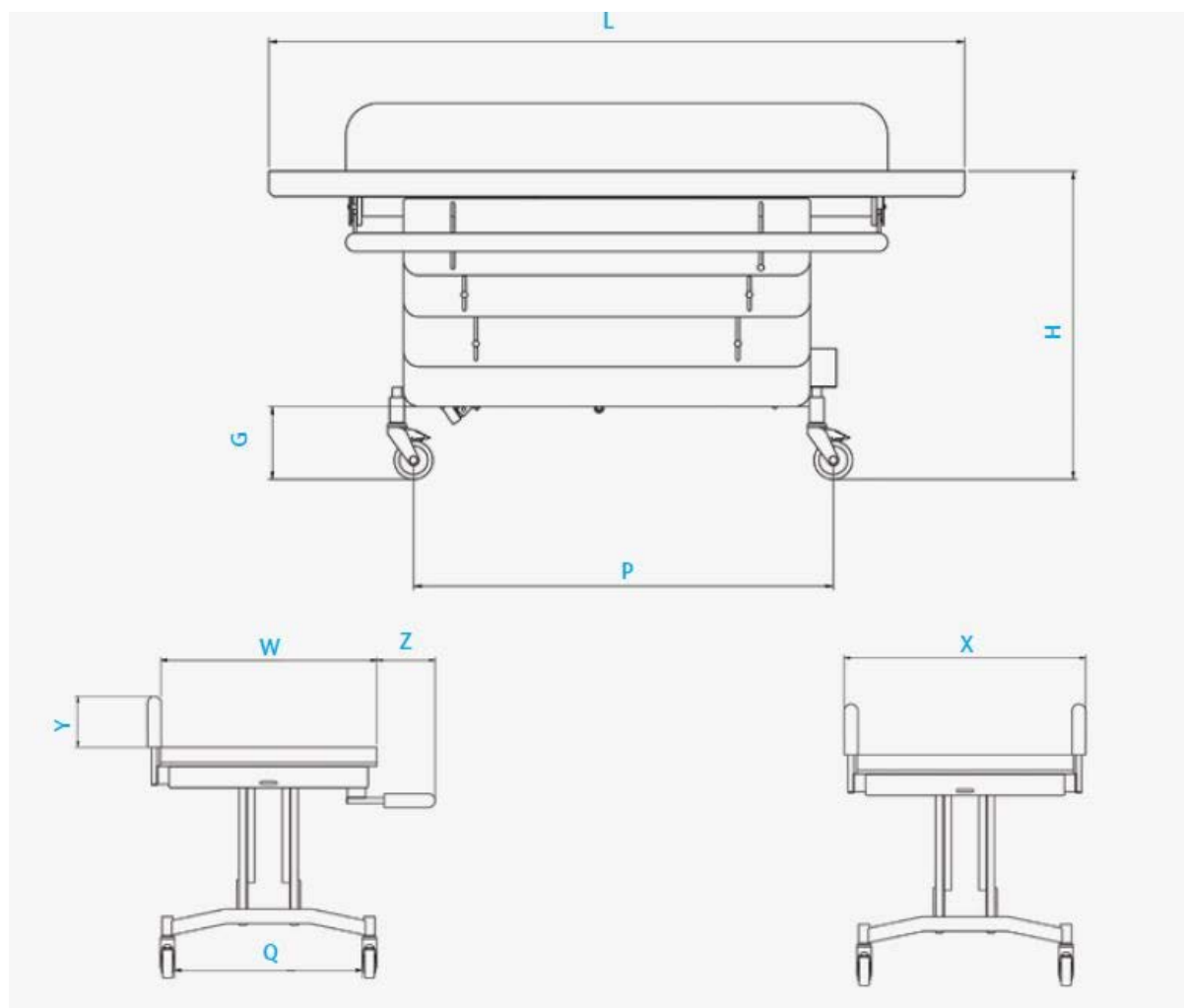

	Mild Steel, Powder Coated			Stainless Steel		
Code	3121	3122	3123	3141	3142	3143
Size	1	2	3	1	2	3
User Weight (kg)	125	125	125	125	125	125
Height Range (mm)	470-950	470-950	470-950	470-950	470-950	470-950
Table Dimensions						
Length (mm)	1400	1600	1800	1400	1600	1800
Width (mm)	750	750	750	750	750	750
Safety Sides						
X (mm)	840	840	840	840	840	840
Y (mm)	165	165	165	165	165	165
Z (mm)	200	200	200	200	200	200
Castor Centres						
P (mm)	1090	1090	1090	1090	1090	1090
Q (mm)	700	700	700	700	700	700
Clearance						
G (mm)	190	190	190	190	190	190
Shipping Weight (kg)	86	88	90	86	88	90



4.0 FOR YOUR SAFETY



STOP!

Please read these instructions **CAREFULLY** and **THOROUGHLY**

- The user should **NOT** be left unattended whilst on the changer. Always ensure a responsible therapist or carer is in attendance.
- The Mobi changer height should **NEVER** be adjusted without a carer in attendance.
- **DO NOT** install the wall mounted charger unit in a wet room environment
- The Mobi changer should **NOT** be used as a transit system.
- Avoid pushing the changer over uneven or rough floors.
- Always keep this product away from naked flames, cigarettes and sources of heat including open fireplaces, radiators and heaters.
- Regular maintenance checks and cleaning are essential for the safe use of this equipment (see care and maintenance section).
- **DO NOT** fit parts or accessories of other manufacturers to this product unless authorised to do so in writing by Smirthwaite Ltd. Failure to follow these instructions will not only invalidate the guarantee but could make the product dangerous to use. Smirthwaite Ltd will not accept liability for any injury or damage incurred through such malpractices. Any repairs required must be carried out by Smirthwaite Ltd authorised personnel.
- If any part is loose, damaged or functioning incorrectly, **DO NOT** use until rectified.
- The Mobi changer is CE marked. This certifies that it meets all relevant European safety requirements.
- If you believe the product or any fitted accessory to be faulty at any time, **DO NOT USE** – contact Smirthwaite by telephone on +44 (0)1626 835552



IMPORTANT!

For side transfers always ensure the safety side is in the fully stowed position. After the user has been transferred into the Mobi changer, please ensure safety sides are in the fully upright position and locked in place before trolley is used.



5.0 UNPACKING YOUR MOBI CHANGER



STOP!

Due to the weight of the changer, care should be taken with the initial handling – it is strongly recommended that two people lift the trolley out its packaging.

- When delivered, the changer will be at its minimum height; the safety sides will be stowed under the bench.
- Please take note of any instructions on the packaging/box when unpacking.
- Place the changer on the floor with the castors locked.
- Check section 2.0 to confirm all parts/items have been delivered.
- If any part is loose, damaged or functioning incorrectly – do not use until rectified.



6.0 SETTING UP AND ADJUSTING YOUR MOBI CHANGER



IMPORTANT!

Always lock the castors when attaching items, or making adjustments. To lock, apply foot to point (A); to unlock, apply foot to point (B).

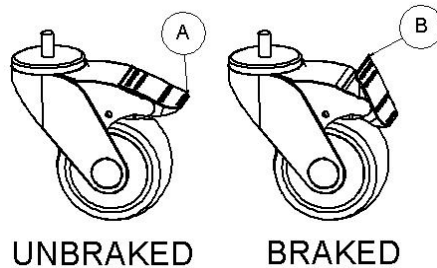

6.1 ELECTRICAL SYSTEM REFERENCE

- The Mobi Changer is supplied with a control box (mounted to the end of the lower frame), a rechargeable battery and a wall mounted charger.
- The wall mounted charger **MUST NOT** be situated in a wet room environment.
- A mounting bracket is provided to assist with the mounting of the charger in a suitable position.
- The wall mounted charger is powered by a 100-240V AC 50/60Hz supply.

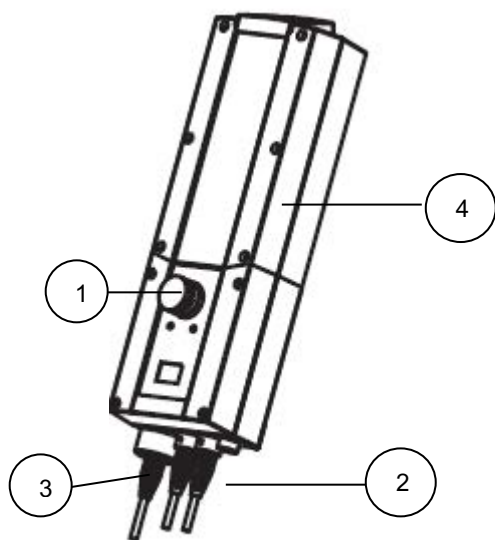

#	Main Control Box
1	Emergency stop
2	Actuator cables (left hand socket used)
3	Handset cable
4	Battery (removable)

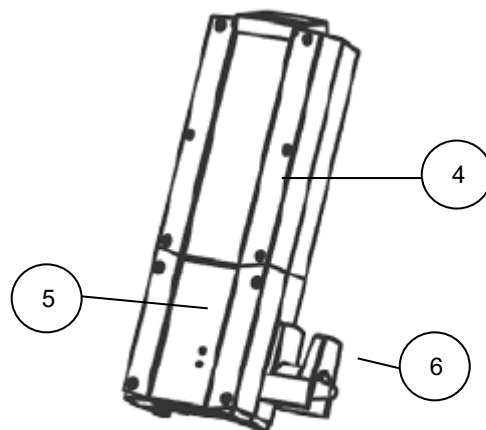

#	Wall Mounted Charger
5	Charger
6	Cable tidy
4	Battery (removable)



6.2 CHARGING YOUR MOBI CHANGER



IMPORTANT!

The battery should be charged for at least 8 hours upon receipt by connecting the battery to the supplied wall mounted charger.

- The rechargeable battery can be un-clipped from the main control box assembly on the Mobi Changer and placed onto the wall mounted charger.
- A green light on the charger will indicate the charger is connected to the AC mains supply
- A second light will light in yellow when the battery is being charged.
- For routine use, the battery should be charged **daily**, for a period of **4 hours**.
- An audible alarm will sound when the battery has discharged to approximately 25% charge level through use.
- Sufficient charge is held in the battery in reserve to permit emergency lowering of the bed.

6.3 CONTROL BOX

- An emergency stop button (RED) is situated on the control box; when depressed this halts the operation of the bed – to enable the Mobi Changer to operate again, simply twist the emergency stop button to reset
- Duty cycle: Max 10% (or 2 minutes) continuous use, then 18 minutes without use.
- The control box system has been designed for operating ambient temperature of +5°C to +40°C

6.3 RAISING THE SAFETY SIDES

- Pull the safety side fully outwards (Z,Y)
- Swing it to the vertical position (X)
- Lift it up fully, and allow it to drop a small distance, locking it into the vertical position (X)
- Repeat for the second safety side

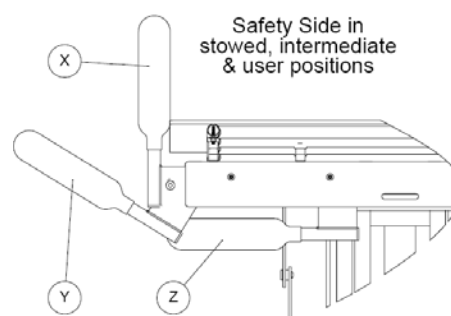

7.0 HOW TO USE YOUR MOBI CHANGER



IMPORTANT!

Ensure all steps of Section 6 are completed before use.

7.1 WHEELCHAIR TRANSFER

- Lift the safety side up and swing to horizontal position
- Stow the safety side under the table
- Lower the table to height of the wheelchair seat
- It is now possible to transfer the user onto the trolley



SAFETY SIDE DOWN



SAFETY SIDE UP

7.2 HOIST TRANSFER

- Transfer patient onto table
- Ensure liner and safety sides are in the 'up' position



8.0 CARE AND MAINTENANCE



IMPORTANT!

Cleaning is recommended on a regular basis

- To clean Mobi Change, use a damp soft cloth with mild soap
- Rinse with clean cloth and water
- DO NOT soak/immerse any part of the product in water
- DO NOT use solvents, abrasives, synthetic detergents and wax polishes
- ALWAYS wipe dry after use
- ALWAYS keep this product away from naked flames, cigarettes and sources of heat including open fireplaces, radiators and heaters
- For further information please refer to MHRA or Local Authority cleaning guidelines

8.1 MAINTENANCE CHECKS



IMPORTANT!

Regular maintenance checks are required

8.1.1 DAILY CHECKS

- **CHECK THAT THE BATTERY IS FULLY CHARGED**
- Check the accessories for damage or loose connection points
- Check all upholstery for signs of wear and tear
- Check the castors are running freely and brakes are in full working order
- Keep the upholstery, wooden and metal parts clean
- Check that all clamping and positional components are working, secure and free from damage

8.1.2 MONTHLY CHECKS

- Repeat daily checks
- Additionally, check all mechanical movements operate fully
- Additionally, check structure for signs of damage or wear and tear

8.2 SERVICE INTERVAL

The Mobi Changer should be serviced every 1 year. Servicing must only be undertaken by a Smirthwaite service engineer, or by a Smirthwaite trained representative.



8.3 NOMINAL SERVICE LIFE

Your product has a nominal service life of 7 years, during which full post-sales support will be available with regard to spares and servicing.

Product service life has been determined based upon the design complexity of product, and the anticipated exposure to normal use.

Good practice dictates all Smirthwaite products have been designed and manufactured to high levels of safety and quality, and will meet requirements of normal use when maintained in line with our servicing recommendations.



STOP!

If the product has been out of use for an extended period of time (6 months or more) it should always be serviced prior to being reissued.

If the product has been subjected to 'heavy' or 'constant' use, the service should be reduced to half the recommended period.

Constant and/or heavy use is considered to be:

- Daily use above 7 hours duration
- Weekly use above 5 days duration
- Monthly use above 10 months per year
- Use by a client who is at 90% to 100% of the maximum weight limit of the product. The maximum weight limit must **NEVER** be exceeded
- Use by a client who is extremely active, either voluntarily or involuntarily

8.4 EXTENDING NOMINAL SERVICE LIFE

At Smirthwaite we are proud to produce products that have a reputation for quality and durability.

We believe our products have the potential to provide benefits to our clients beyond the nominal service life documented above.

We will continue to provide full support beyond the nominal service life provided the following conditions are met:

1. A full service schedule has been maintained. A full service and inspection is undertaken at the end of the nominal service life period
2. The product is subsequently serviced annually (or biannually if under 'heavy/constant' use conditions)
3. Smirthwaite reserve the right to limit support where parts/components are no longer available



8.5 DOCUMENTATION/RECORDS

- It is the responsibility of the current equipment owner to ensure the 'Instructions for Use' manual and any further manuals for accessories fitted to the equipment are handed over to the new owner at the time of exchange/sale
- It is the responsibility of the current equipment owner to ensure the service and inspection record form is kept up to date

8.6 PRODUCT CONFIGURATION

- Smirthwaite will document and maintain a record of the original product configuration at the time of first sale
- Smirthwaite will not be held responsible for any subsequent changes to this configuration unless authorized to do so in writing by Smirthwaite Ltd
- It is the equipment owner's responsibility to maintain their own records of changes to the equipment configuration and to be able to provide such records to subsequent owners to maintain traceability
- We recommend an inspection/service by a Smirthwaite Service Engineer (or Smirthwaite trained engineer) whenever a significant change is made to product configuration to ensure the product is safe to use. **If in any doubt, ALWAYS seek ADVICE**



IMPORTANT REMINDER!

DO NOT fit parts or accessories of other manufacturers to this product unless authorized to do so in writing by Smirthwaite Ltd.

Any servicing or repairs required must be carried out by Smirthwaite Ltd (or a Smirthwaite trained engineer).

If you believe this product to be faulty – DO NOT USE – Contact Smirthwaite Ltd on T: +44 (0) 1626 835552

If in any doubt, ALWAYS seek ADVICE.



8.7 EUROPEAN DIRECTIVE 2002/96/EC - WASTE ELECTRICAL AND ELECTRONIC EQUIPMENT (WEEE)

The Waste Electrical and Electronic Equipment Directive (WEEE Directive) came into force in January 2007. The Directive aims to both reduce the amount of electrical and electronic equipment being produced and to encourage everyone to reuse, recycle and recover it.

As the responsible manufacturer, Smirthwaite operate a 'take back' scheme wherein we accept electrical and electronic components returned to our factory at the end of their product service life.

Please note, we are obligated only to accept the return of electronic/electrical components for responsible recycling, not complete products or assemblies.

Please contact Smirthwaite Ltd on T: +44 (0) 1626 835552 should you require any further information.



9.0 WARRANTY & SERVICE

Smirthwaite Ltd warrants the products detailed on your order to be free from defects in materials and workmanship for a period of 2 years from date of delivery. If a fault develops during the period, please call Customer Services by email or telephone 01626 835552 who will advise you on the best course of action. Possible action may be for us to arrange to send out one of our Service Engineers, or have the goods returned to us. Should a repair not be possible within the guarantee period we will replace the product for new or nearest equivalent product. In the unlikely event that we cannot repair or exchange we will refund in full.

This warranty is for the UK only. The warranty excludes faults due to accident, neglect, misuse, not following the Instructions and normal wear and tear. This warranty is in addition to your legal rights. Goods will only be collected from the original delivery address.

A charge may be made where the goods cannot be repaired under the terms of the warranty. You will be advised before this is made.

T: +44 (0)1626 835552 E: info@smirthwaite.co.uk

10.0 CONTINUOUS IMPROVEMENT

Smirthwaite Ltd are committed to continuous improvement to their product range. Should you have any suggestions or comments please send them to our product design department at: info@smirthwaite.co.uk

Smirthwaite Ltd reserve the right to change the specification or material without prior notice.

For catalogues, help and further information on our products please contact us at:

Smirthwaite Ltd 16 Wentworth Road Heathfield, Devon.TQ12 6TL

T: +44 (0)1626 835552

F: +44 (0)1626 835428

E: info@smirthwaite.co.uk

W: www.smirthwaite.co.uk



11.0 SERVICE INSPECTION

11.1 Product Information

Model:	
Size:	
Date of Manufacture:	
Serial Number:	
Final Inspection	

11.2 Service & inspection record form:

Date	Procedure	Service Personnel





Smirthwaite, 16 Wentworth Road, Heathfield, Newton Abbot, Devon.TQ12 6TL
T: +44 (0) 1626 835552 F: +44 (0) 1626 835428 E: info@smirthwaite.co.uk www.smirthwaite.co.uk

