

130 Mobile Hoist



Weights & Dimensions

SWL	130kg
Unit weight	40kg
Base weight	18.5kg
Mast & boom weight	21.5kg
A (height)	1,340 – 2,010 mm
B (length)	1,235 mm
C (internal width)	500 – 1,100 mm
D (external width)	620 – 1,150mm
E (ground clearance)	15 mm
F (under bed clearance)	100 mm
G (Carry bar height)	380 – 1,750 mm
Carry bar width	620 mm
Turning circle	1,010 mm
Castor size (front, back)	75,100 mm

Details

Warranty	5 years
Sling connection	Looped
Lift	Electric (LA40 – 8 kN)
Leg opening	Electric (LA23 – 8 kN)
Hand controls	Wired electric hooked handset
Control box	Standard (no screen)
Duty cycle	15% use, 85% rest
Battery	24 V SLA, 2.9 Ah
Changing time	8 hours
IP rating (controls)	IPX4
IP rating (battery)	IPX5
Material	Powdercoated steel, vinyl PVC

Standards

ISO 10535:2006
IEC 62366-1:2015
EN ISO 15223-1:2016
IEC 60601-1:2012
IEC 60601-2:2014

Contact

6 Wentworth Road, Heathfield,
Newton Abbot, Devon,
TQ12 6TL

+44 (0) 1626 835 552
info@smirthwaite.co.uk

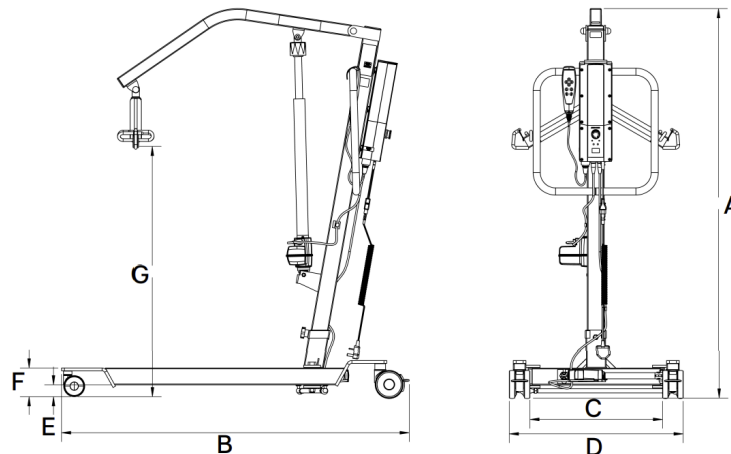

130 Datasheet